

Experiment No 9.

Design of Half Adder circuit using
gates

BEEE102P
Basic Electrical and Electronics Engineering Lab
List of Experiments

Cycle-1 Software Experiments

S.No	Experiment Title
1	Verification of Mesh current analysis and node voltage analysis using ORCAD/Capture CIS
2	Verification of Thevenin's theorem using ORCAD/Capture CIS
3	Verification of Maximum power transfer theorem using ORCAD/Capture CIS
4	Verification of Resonance phenomenon in a series RLC circuit using ORCAD/Capture CIS using AC Parametric Sweep Analysis
5	Design of single-phase half-wave and full wave rectifier
Cycle-II Hardware Experiments	
6	Verification of Kirchhoff's current law/ Thevenins theorem
7	Thevenin's theorem verification
8	Design of regulated power supply using Zener diode
9	Design of half adder circuit using logic gates
10	Wiring circuit for Single lamp and Fan with regulator/ Staircase wiring circuit layout of multi storage building

AND Gate

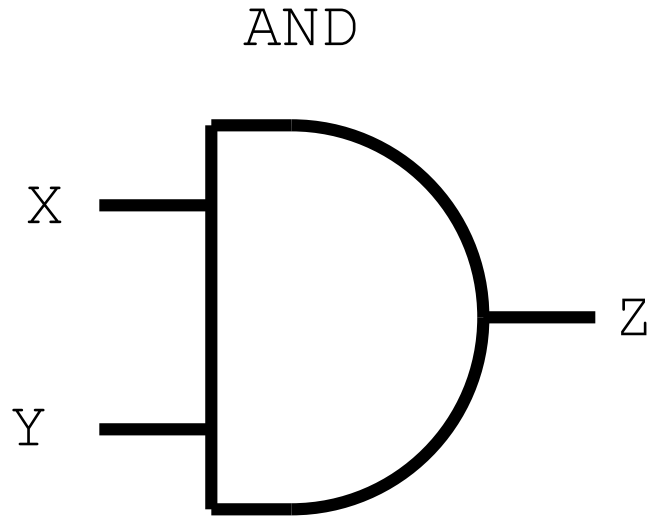

X	Y	Z
0	0	0
0	1	0
1	0	0
1	1	1

$$Z = X \& Y$$

OR Gate

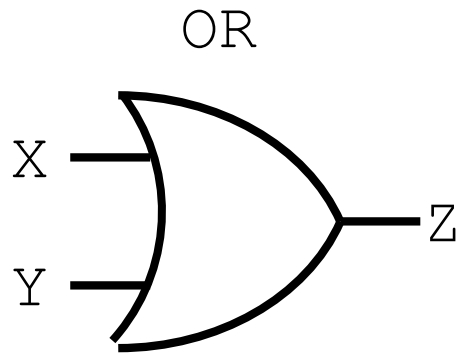

$$Z = X \mid Y$$

X	Y	Z
0	0	0
0	1	1
1	0	1
1	1	1

XOR (Exclusive OR) Gate

$$Z = X'Y + XY'$$

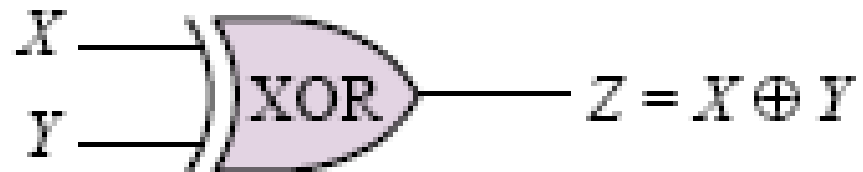

$$Z = X \oplus Y$$

X	Y	Z
0	0	0
0	1	1
1	0	1
1	1	0

Truth table

Binary number system

Decimal	Binary
0	00
1	01
2	10
3	11

Half Adder

Half Adder: is a combinational circuit that performs the addition of two bits, this circuit needs two binary inputs and two binary outputs.

Inputs		Outputs	
X	Y	C	S
0	0	0	0
0	1	0	1
1	0	0	1
1	1	1	0

Truth table

The simplified Boolean function from the truth table:

$$\left. \begin{array}{l} S = \bar{X}Y + X\bar{Y} \\ C = XY \end{array} \right\} \text{(Using sum of product form)}$$

Where **S** is the sum and **C** is the carry.

$$\left. \begin{array}{l} S = X \oplus Y \\ C = XY \end{array} \right\} \text{(Using XOR and AND Gates)}$$

Half Adder Truth Table:

Inputs		Outputs	
X	Y	S	C-out
0	0	0	0
0	1	1	0
1	0	1	0
1	1	0	1

$$S(X, Y) = \Sigma (1, 2)$$

$$S = X'Y + XY'$$

$$S = X \oplus Y$$

$$C\text{-out}(x, y, C\text{-in}) = \Sigma (3)$$

$$C\text{-out} = XY$$

For Carry

		B
A	0	0
	1	1

$$\text{Carry} = AB$$

For Sum

		B
A	0	1
	1	0

$$\begin{aligned} \text{Sum} &= \overline{A}B + A\overline{B} \\ &= A \oplus B \end{aligned}$$

$$\left. \begin{aligned} S &= \bar{X}Y + X\bar{Y} \\ C &= XY \end{aligned} \right\} \text{(Using sum of product form)}$$

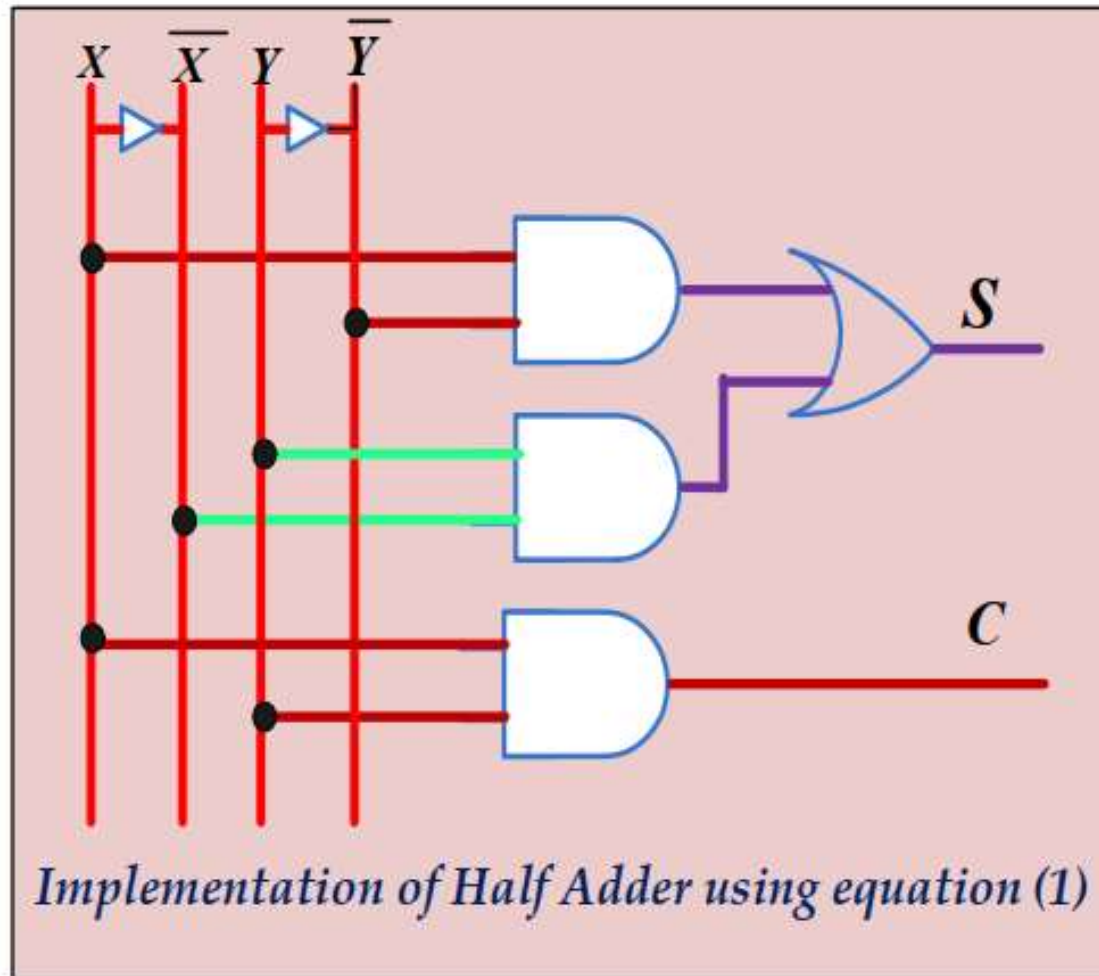

$$\begin{cases} S = X \oplus Y \\ C = XY \end{cases}$$

2} (Using **XOR** and **AND** Gates)

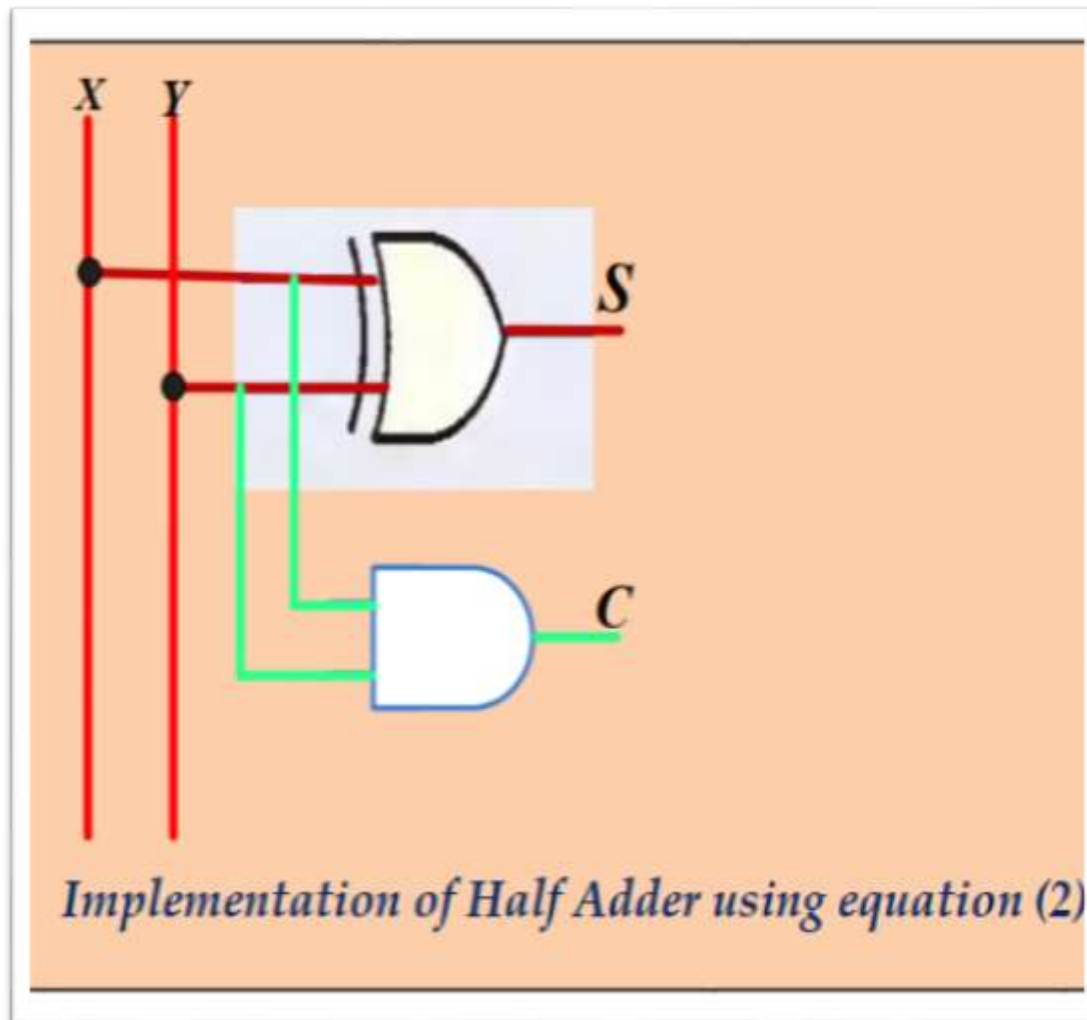

Apparatus/Tool required:

S. No.	Name of the apparatus	Range / Type	Quantity
1	7486 gate XOR	-	1 No.
2	7408 gate AND	-	1 No.
3	LED	-	2 Nos.
4	RPS	0 – 15 V	1 No.
5	Resistor	330 Ω	2 Nos.
6	Breadboard	-	1 No.
7	Wires	-	Few

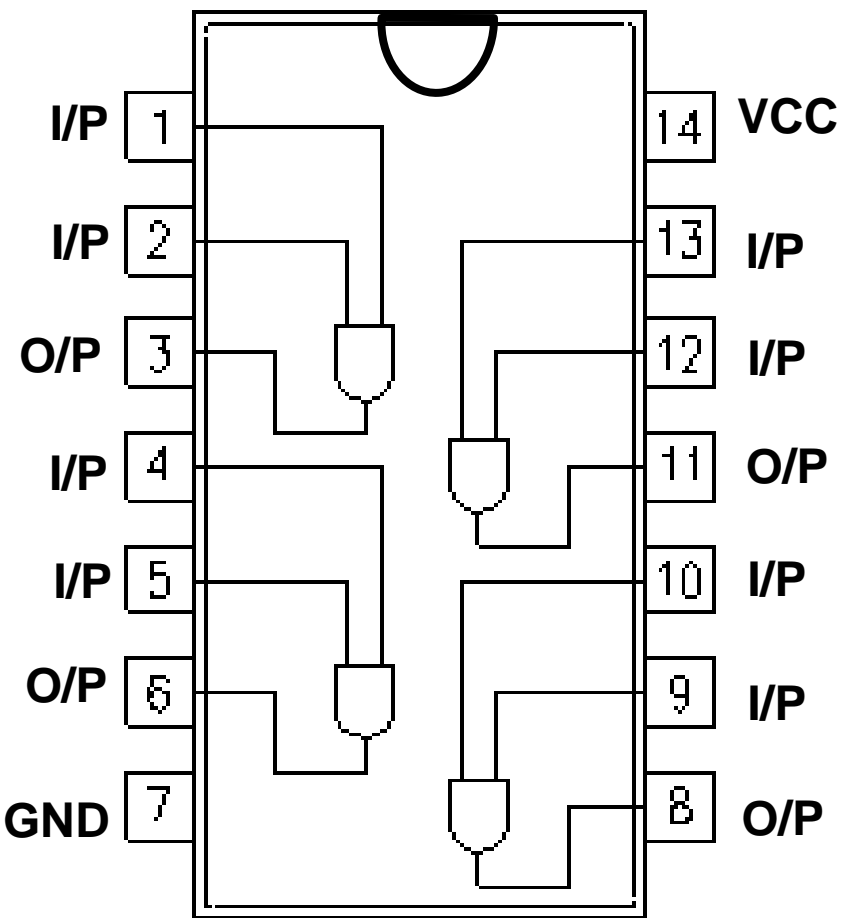

7408
Quad 2-Input
NOR Gate

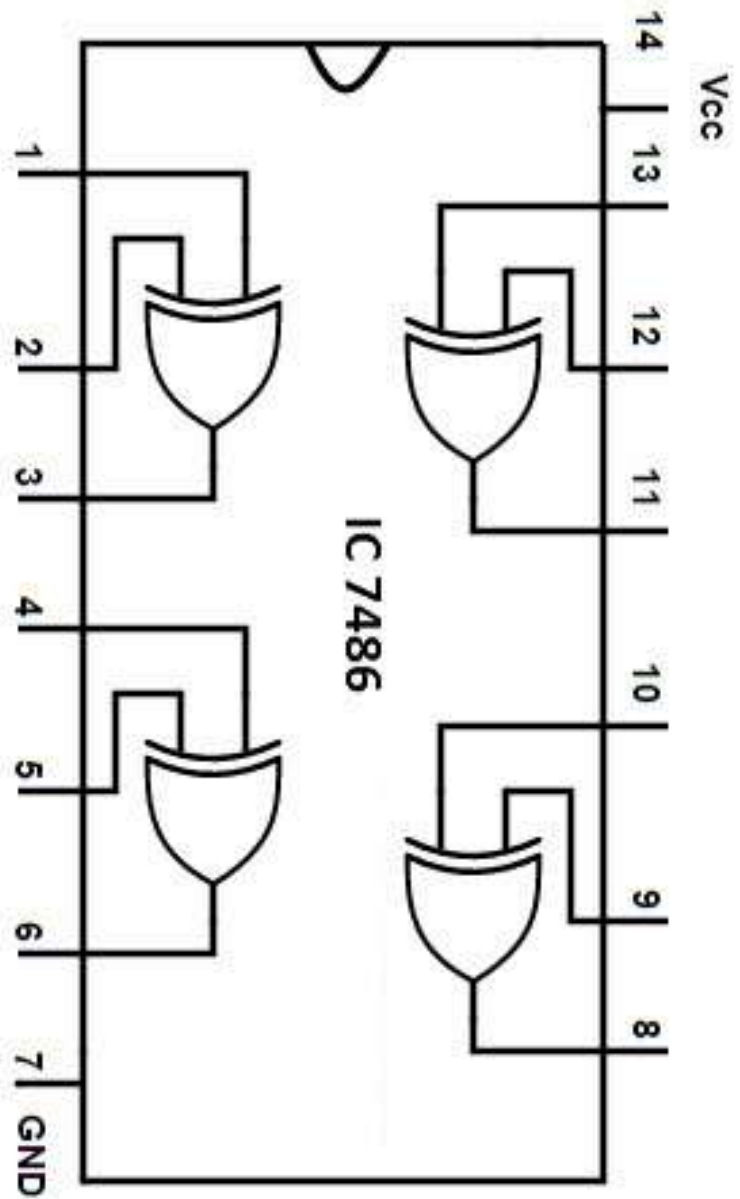

Circuit Diagram:

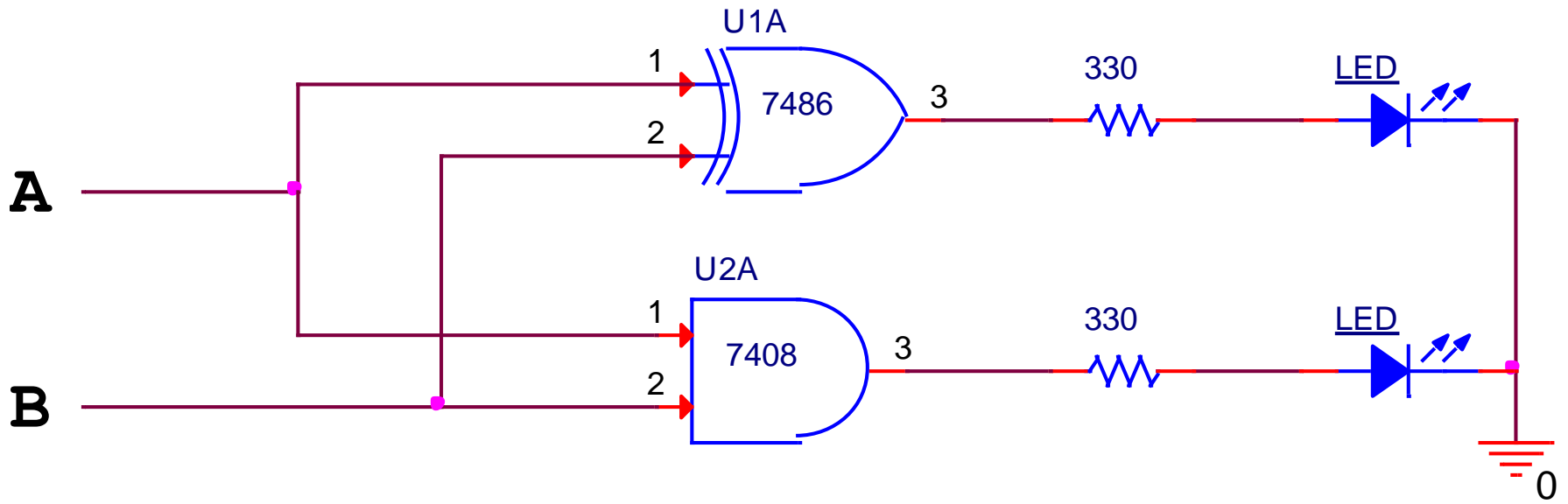

Observation table

A	B	LED 1 (SUM)	LED 2 (CARRY)
0	0	Glowing /not glowing	
0	1		
1	0		
1	1		