



VIT

Vellore Institute of Technology
(Deemed to be University under section 10F UGC Act, 1956)

REG.NO.:

SCHOOL OF COMPUTER SCIENCE & ENGINEERING
CONTINUOUS ASSESSMENT TEST - II
FALL SEMESTER 2024-2025

SLOT: D2+TD2

Programme Name & Branch : B.Tech Computer Science & Engineering
B.Tech Computer Science & Engineering (All Specializations)
Course Code and Course Name : BCSE308L & Computer Networks
Faculty Name(s) : Common for all
Class Number(s) : Common for all
Date of Examination : 16.10.2024
Exam Duration : 90 minutes **Maximum Marks: 50**

General instruction(s):

Answer All Questions

- M - Max mark; CO – Course Outcome; BL – Blooms Taxonomy Level (1 – Remember, 2 – Understand, 3 – Apply, 4 – Analyse, 5 – Evaluate, 6 – Create)
- Course Outcomes
 CO3. Identify and analyze error and flow control mechanisms in data link layer.
 CO4. Design sub-netting and analyze the performance of network layer with various routing protocols.

Q. No	Question	M
1.	a. Assuming N stations are present in pure Aloha Network, having a bandwidth of 56Kb/Sec find the value of N, assuming that each station sends data of size 1000 bits at an average interval of 100 sec. b. X is working as a Business Development Lead in a leading MNC and keeps traveling frequently. X is also given the task to attend online meetings even in transit. An urgent meet was called for when X was about to board his flight and there was a poor network in his mobile. X contacted the helpdesk requesting for internet connection. Which IEEE standard would help to connect to the airline's internet service? Enumerate the architecture involved in connecting to the airline's internet service.	5
2.	An ISP is granted a block of addresses starting with 150.80.0.0/16. The ISP wants to distribute these blocks to customers as follows: Design the subnets i. The first group has 200 medium-size businesses, each need 128 addresses. Find the range of 200 th subnet ii. The second group has 400 small businesses, each need 16 addresses. Find the range of 400 th subnet iii. The third group has 2048 households, each need 4 addresses. Find the range of 2048 th subnet Design the subnets. Find out how many addresses are still available after these allocations	10
3.	a. Consider an IP packet with a length 4500 bytes that includes a 20-byte IPv4 header and a 40-byte TCP header. The packet is forwarded to an IPV4 router that supports a Maximum Transmission unit MTU of 600 bytes. Assume that the length of the header in all the outgoing fragments of this packet is 20 bytes. Assume that the fragmentation offset value store in the first fragment is 0. What is the fragmentation offset stored in the third fragment?	7

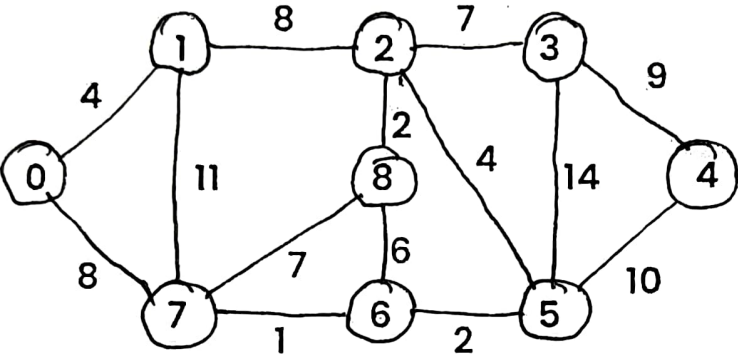
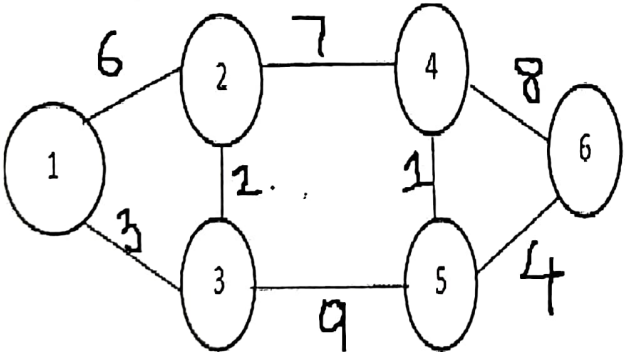

SCHOOL OF COMPUTER SCIENCE & ENGINEERING
CONTINUOUS ASSESSMENT TEST -II
FALL SEMESTER 2024-2025

	<p>b. A CEO of a company needs a privacy in maintaining the number of hosts for his company to the public network with a single IP address. What is the networking technology required for the above and explain the same?</p>	3
4.	<p>Perform Dijkstra algorithm to find the shortest path for Node 0 and Node 4</p> 	10
5.	<p>Consider a network with 6 routers R1 to R6 connected with links having weights as shown in the diagram</p>  <p>i. All the routers use the distance vector routing algorithm to update the routing table. Each router starts with its routing table initialized to contain an entry for each neighbour with the weight of the respective connecting link. Show the routing tables for Router 1 with first and second iteration, also tabulate the final routing table. (7 marks)</p> <p>ii. How many links in the network will never be used for carrying data? State reasons for the same (3 marks)</p>	10
