

MODULE - I

DC CIRCUITS

Contents

- Basic circuit elements and sources
- Ohms law
- Kirchhoff's laws
- Series & Parallel connection of circuit elements
- Mesh current analysis
- Node voltage analysis
- Thevenin's Theorem
- Maximum power transfer theorem.

Basic circuit elements

Electrons
Current
Voltage
Power

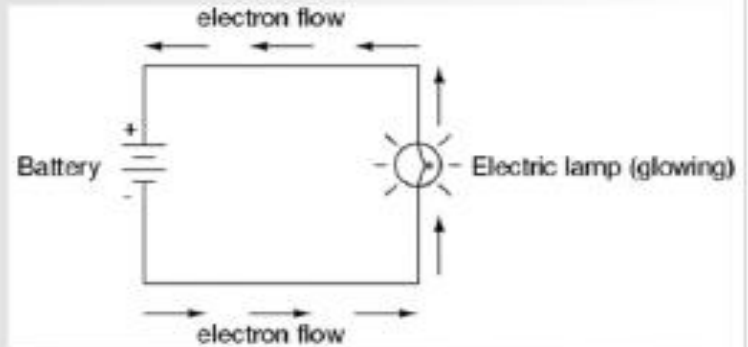
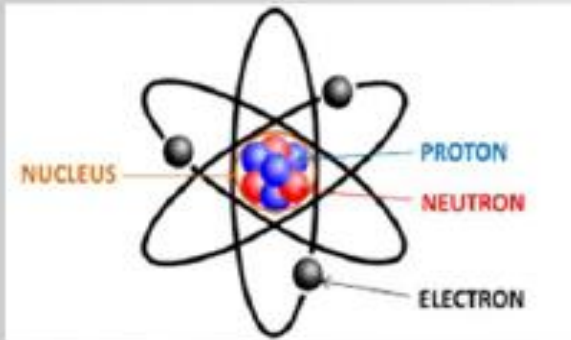

Resistor
Capacitor
Inductor

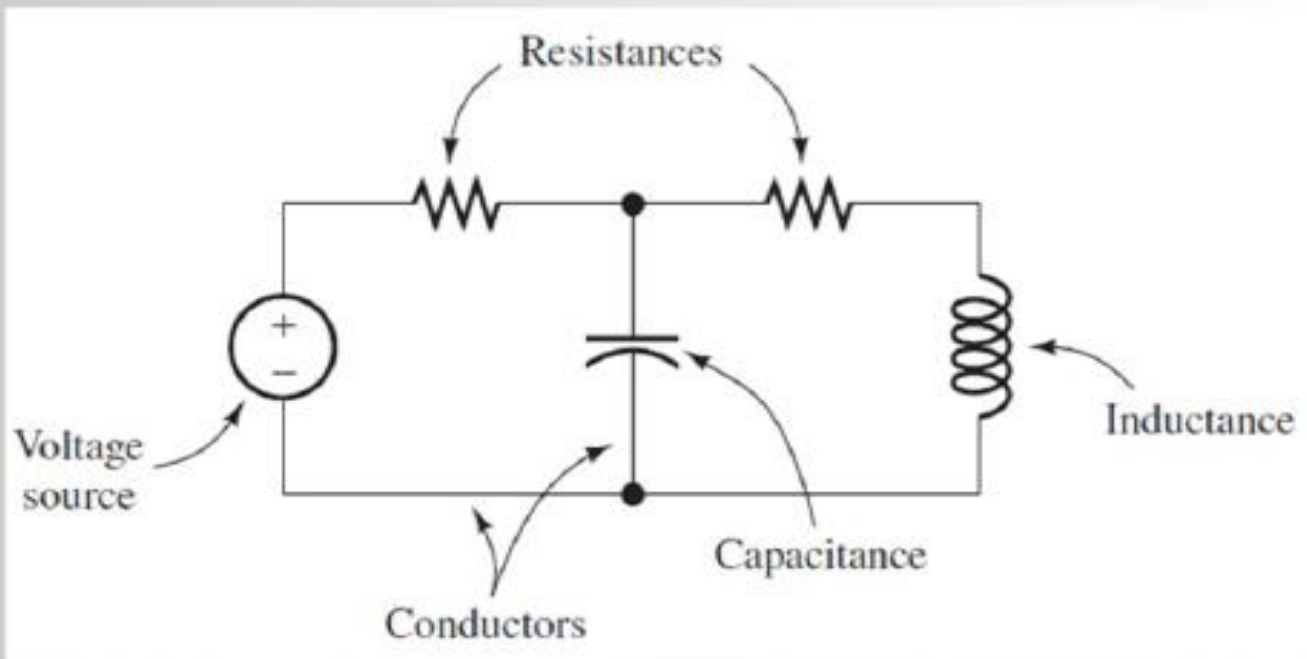

Resistor

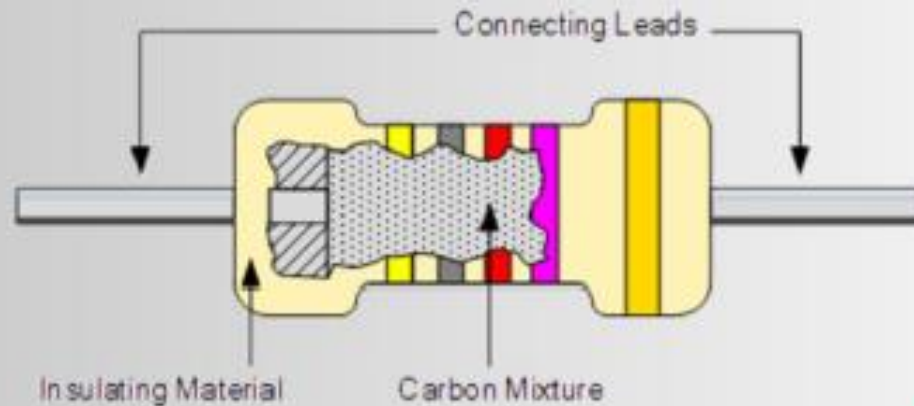

Resistor (R)

Conductor (G)

A resistor is a passive two-terminal electrical component that implements electrical resistance as a circuit element. Resistors are used to reduce current flow, adjust signal levels, to divide voltages, etc.

Resistance (Ohm)

Conductance (Mho)

Defined as the resistance between two points in a conductor when a constant electric potential of one volt applied at the two points produces a current flow of one ampere in the conductor. [1]

The unit of electric resistance is the ohm (Ω)

$$1 \Omega = 1 \text{ Volt} / \text{Ampere}$$

Colour coding of Resistance

$$\text{Resistor value} = AB \times 10^C \pm \text{tol}\%(\Omega)$$

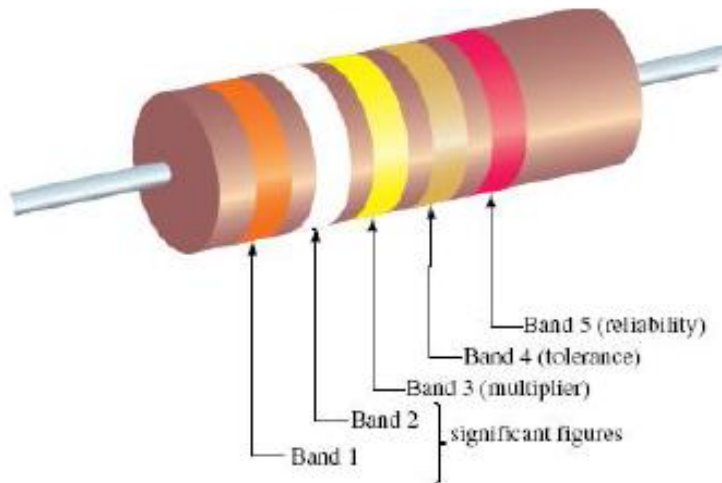

Resistor color codes.

Color	Tolerance
Brown	±1%
Red	±2%
Gold	±5%
Silver	±10%
None	±20%

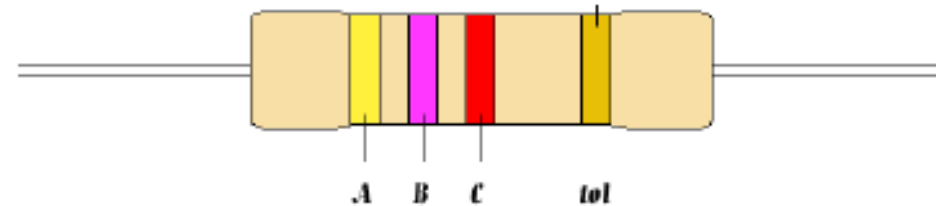

Band color	Digit	Multiplier
Black	0	X1
Brown	1	X10
Red	2	X100
Orange	3	X1000
Yellow	4	X10000
Green	5	X100000
Blue	6	X1000000
Purple	7	X10000000
Grey	8	X100000000
White	9	X1000000000
Silver	-	x.01
Gold	-	x.1

Capacitor

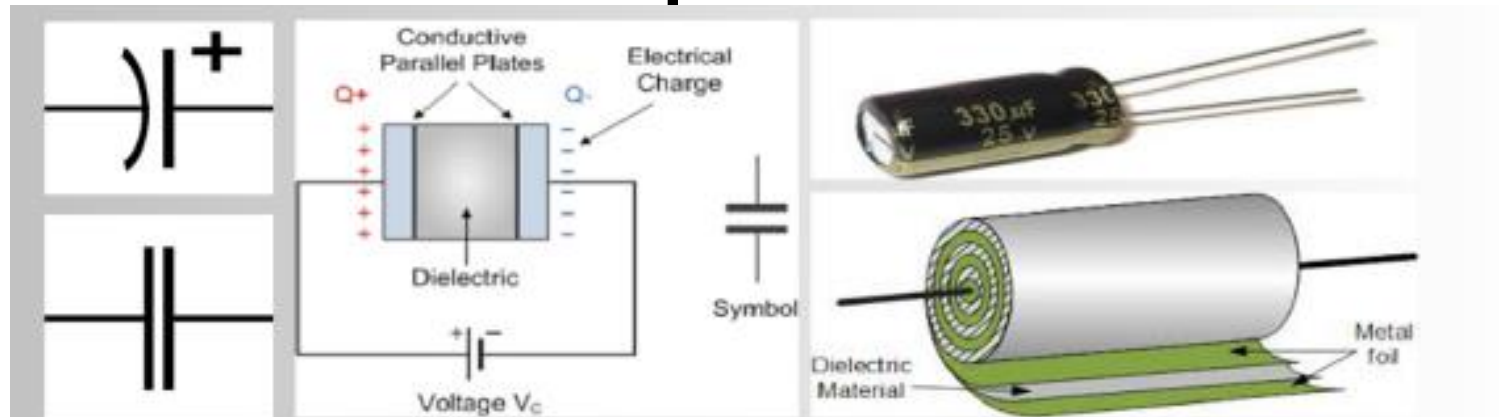

Capacitor (C)

A capacitor is an electrical device that is used to store electrical energy. Devices specially constructed to possess capacitance are called capacitors (or) condensers. In its simplest form a capacitor consists of two plates which are separated by an insulating material known as a dielectric. A capacitor has the ability to store a quantity of static electricity. [T1]

Capacitance (F)

The **unit of capacitance** is the **farad F** (or more usually $\mu\text{F}=10^{-6} \text{ F}$ or $\text{pF}=10^{-12} \text{ F}$), which is defined as the capacitance when a potential difference of one volt appears across the plates when charged with one coulomb.

Property of this pair of plates which determines how much charge corresponds to a given potential difference between the plates is called their **capacitance**:

The unit of Capacitance is Farad (F)

1 F = 1 Columb / Volt

Inductor

A component called an inductor is used when the property of inductance is required in a circuit. The basic form of an inductor is simply a coil of wire.

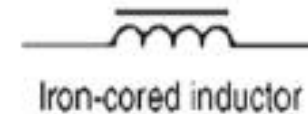
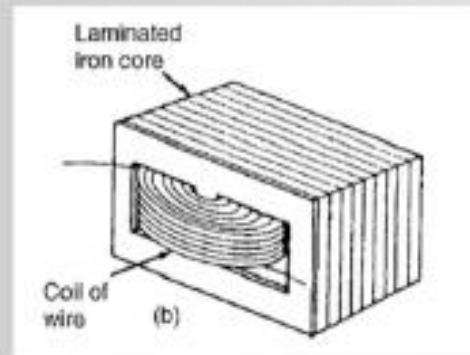
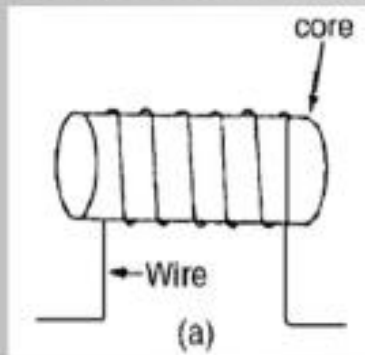

An iron-cored inductor is often called a choke since, when used in a.c. circuits, it has a choking effect, limiting the current flowing through it.

Inductance (H) henry

Inductance is the name given to the property of a circuit whereby there is an e.m.f. induced into the circuit by the change of flux linkages produced by a current change.

A circuit has an inductance of one henry when an e.m.f. of one volt is induced in it by a current changing at the rate of one ampere per second

Electric Circuit

What is an electric circuit?

An electric circuit is an interconnection of electrical elements such as sources and loads through wires (cables).

What is the purpose of electric circuit?

To transmit/deliver power from source to load/one place to another.

A simple electric circuit.

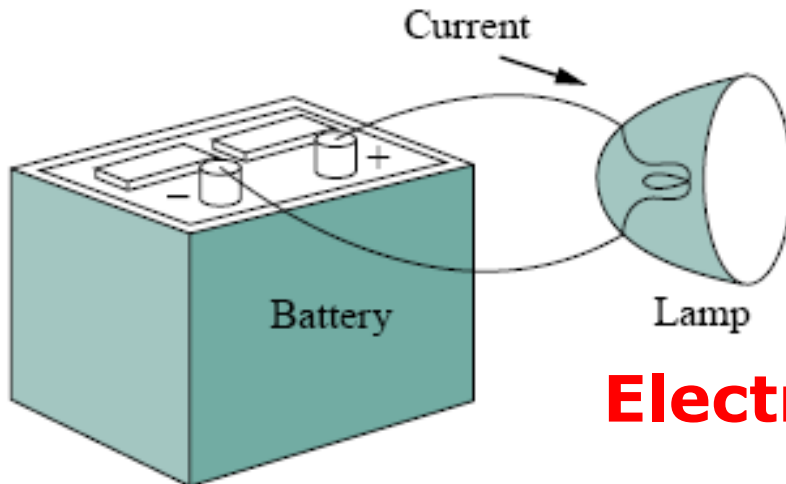

Electric torch

Electric circuit

A closed loop of pathway with electric charges or current flowing through it.

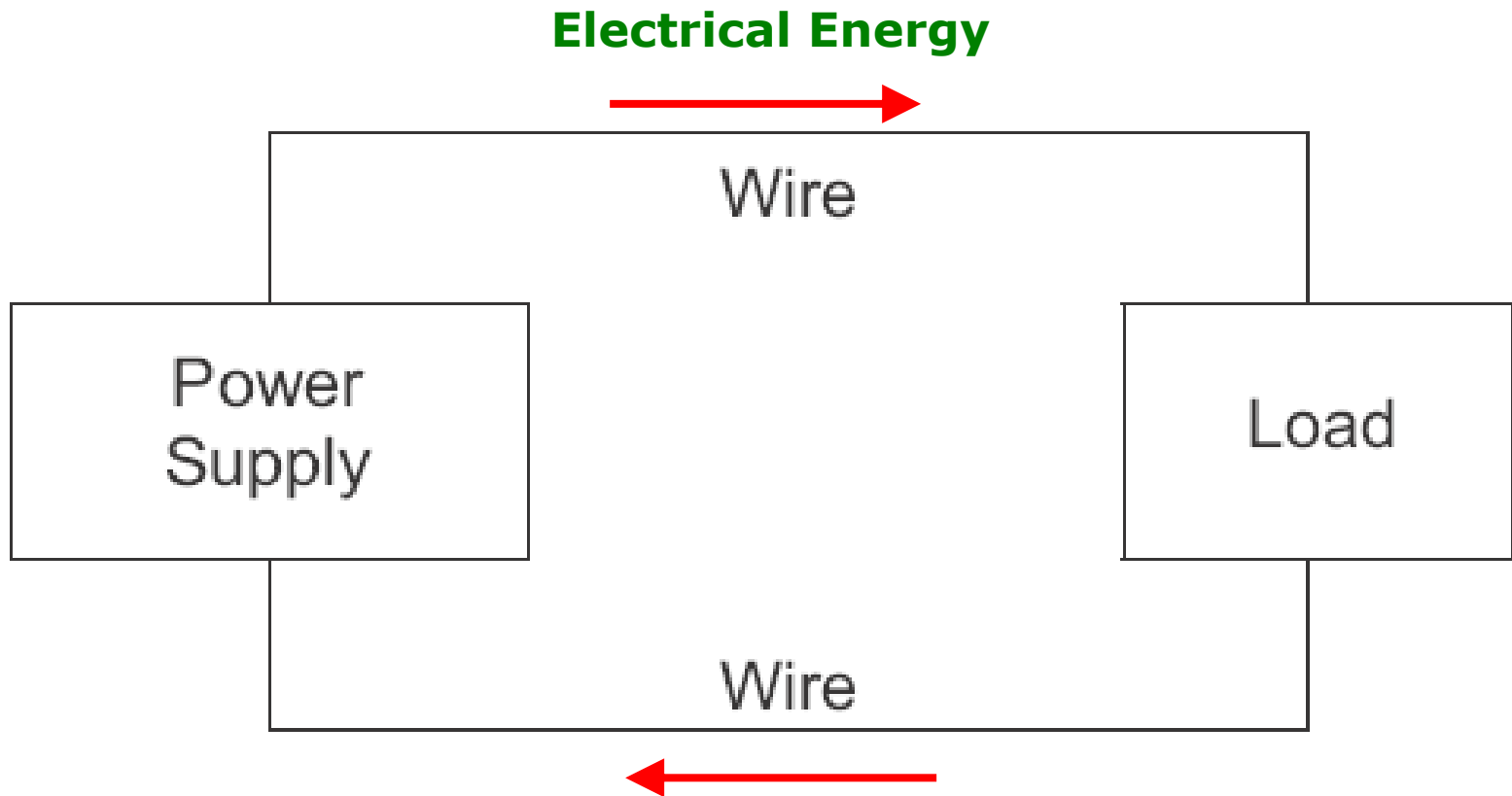

The **most basic quantity** in an electric circuit is the **electric charge**. Charge is an electrical property of the atomic particles that the charge e on an electron is negative and equal in magnitude to 1.602×10^{-19} C, while a proton carries a positive charge of the same magnitude as the electron.

The coulomb is a large unit for charges. In 1 C of charge, there are $1/(1.602 \times 10^{-19}) = 6.24 \times 10^{18}$ electrons.

Electric current is the time rate of change of charge, measured in amperes (A).

A **direct current** (dc) is a current that remains constant with time.

An **alternating current** (ac) is a current that varies sinusoidally with time.

Voltage (or **potential difference**) is the energy required to move a unit charge through an element, measured in volts (V).

Power is the time rate of expending or absorbing energy, measured in watts (W).

Analogous circuit

Current-Water Analogy

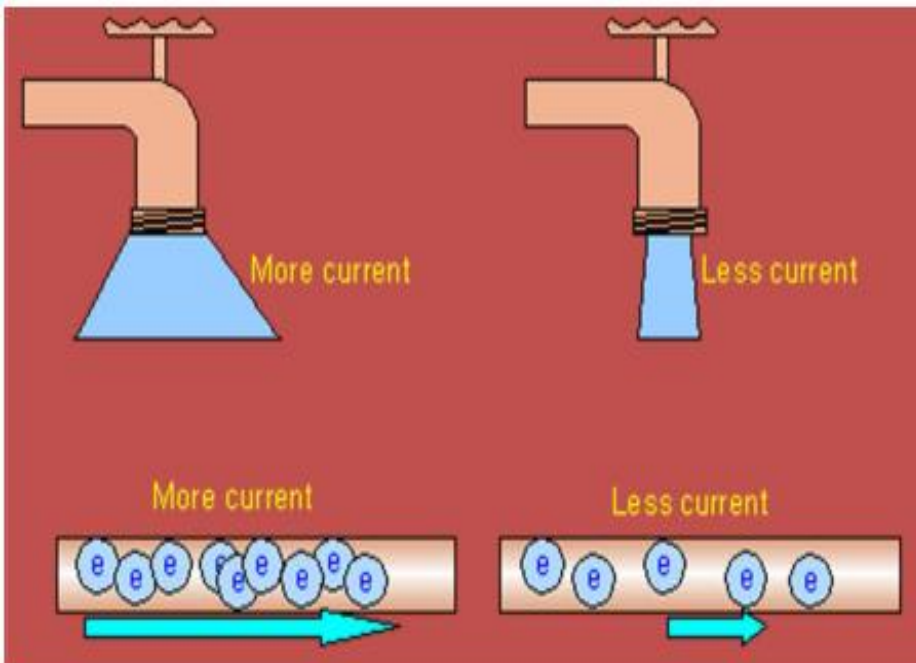

Voltage-Water Analogy

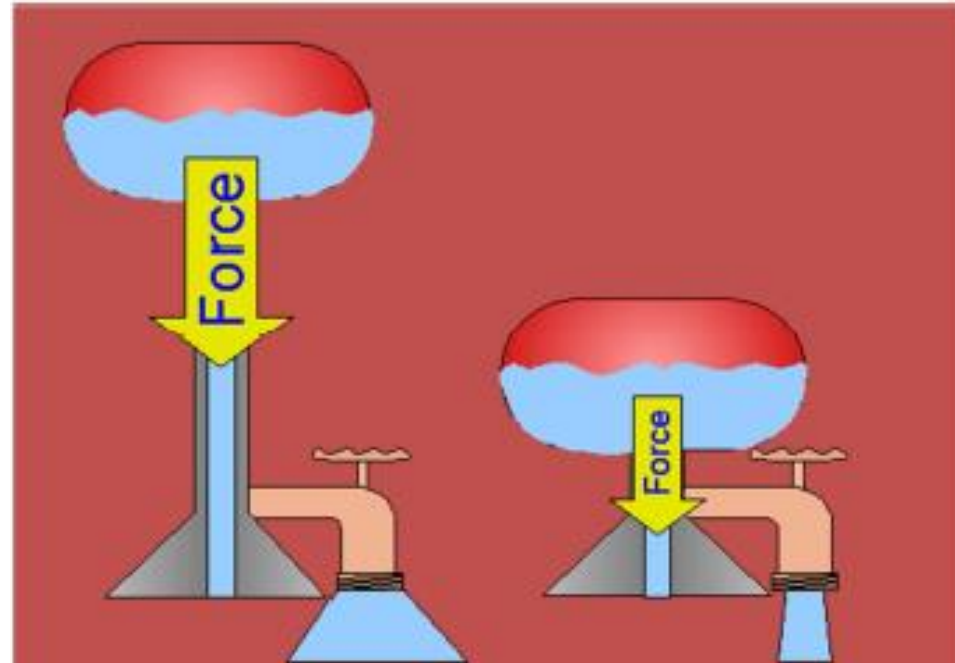

Classification of Elements & sources

There are two types of elements in electric circuits:

Passive elements and Active elements.

An **active element** is capable of generating energy while a passive element is not.

Examples of passive elements are resistors, capacitors, and inductors.

Typical active elements include generators, batteries, and operational amplifiers.

The most important active elements are voltage or current sources that generally deliver power to the circuit connected to them.

There are two kinds of sources: **independent and dependent sources.**

Nodes and Branches

- Node: A connection point of one or more circuit elements
End point of a branch
- Branch: A two-terminal circuit element between two nodes
A line segment between two nodes
- A loop is any closed path through a circuit in which no node is encountered more than once (ABCA)

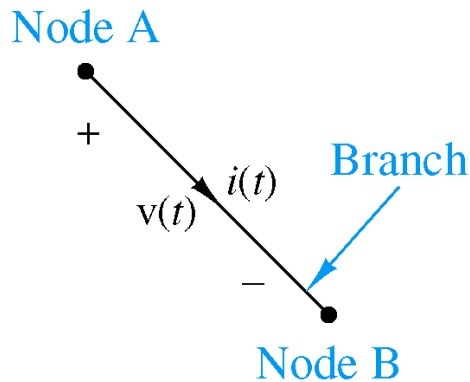

(a)

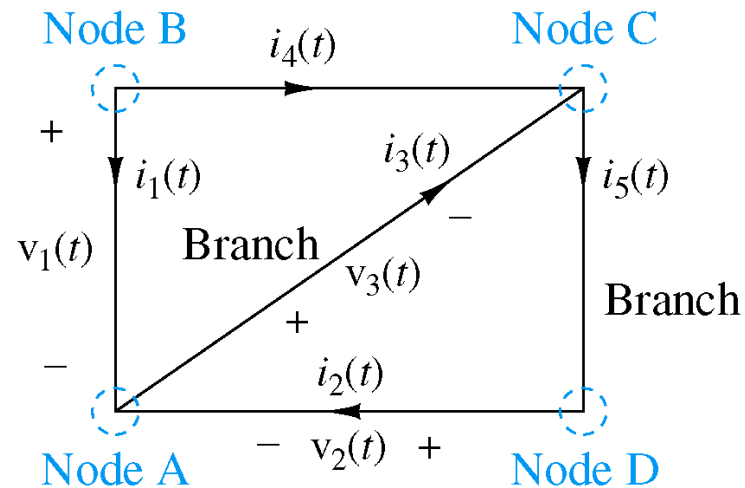

(b)

Independent sources

An ideal independent source is an active element that provides a specified voltage or current that is completely independent of other circuit variables.

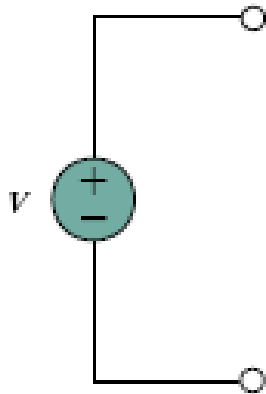

(a)

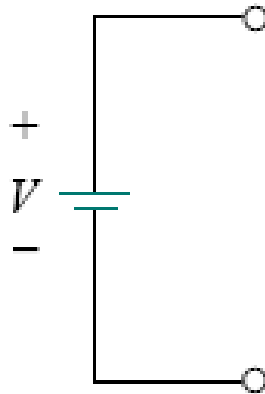

(b)

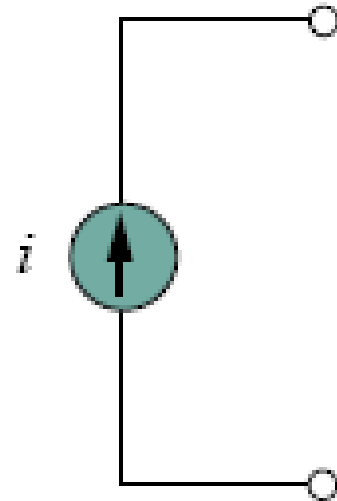

Ideal and Practical Voltage Sources

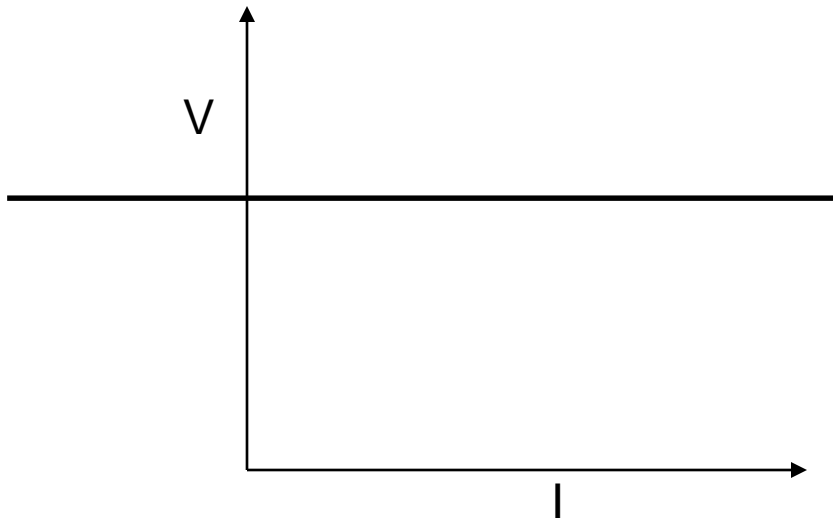

IDEAL VOLTAGE SOURCE

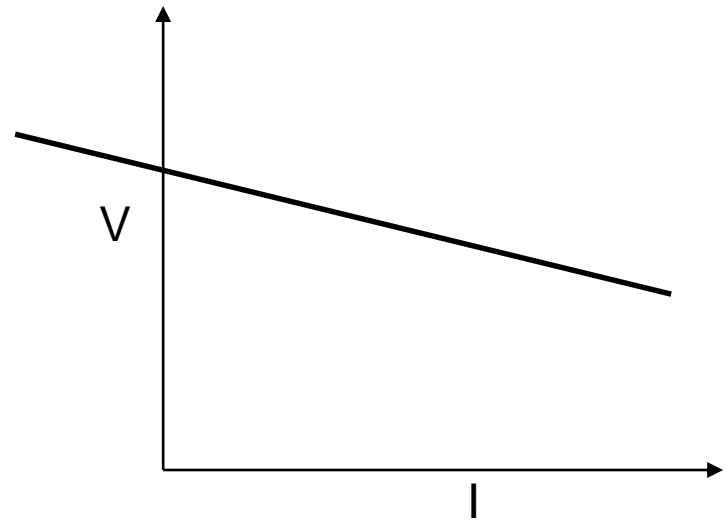

PRACTICAL VOLTAGE SOURCE

Note that an ideal voltage source can supply arbitrarily large currents without any decrease in voltage.

Ideal and Practical Current Sources

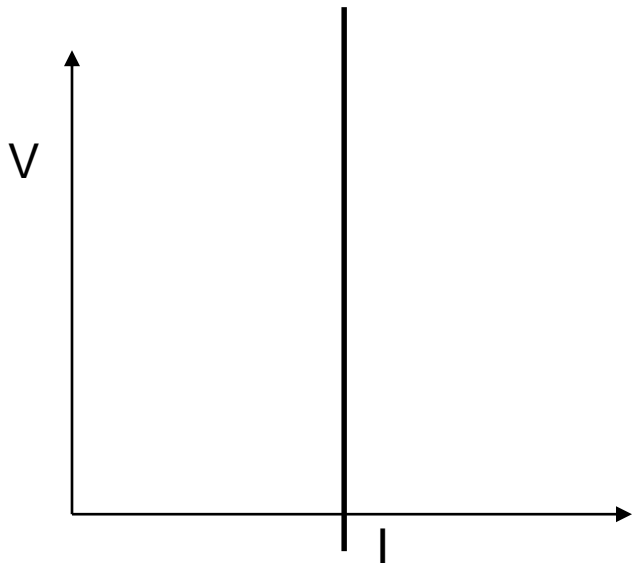

IDEAL CURRENT SOURCE

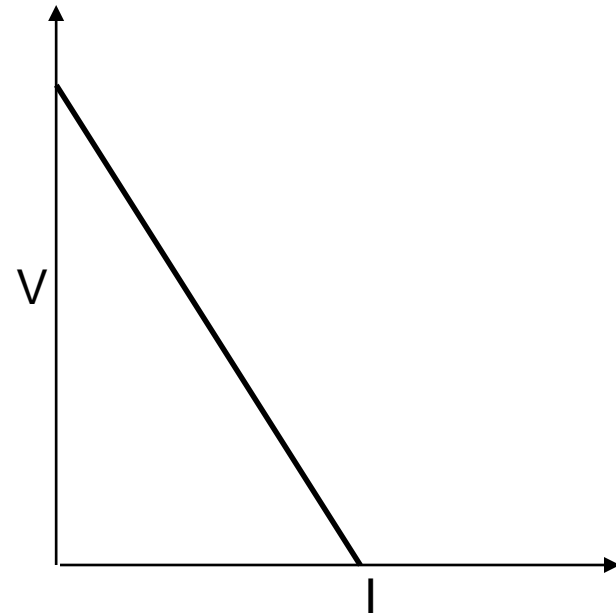

PRACTICAL CURRENT SOURCE

Note that an ideal current source can supply arbitrarily large voltages without any decrease in current.

Dependent sources

A **dependent source** is a **voltage source or a current source** whose value depends on a voltage or current somewhere else in the network. **Dependent sources** are useful, for example, in modelling the behavior of amplifiers, transistors etc.



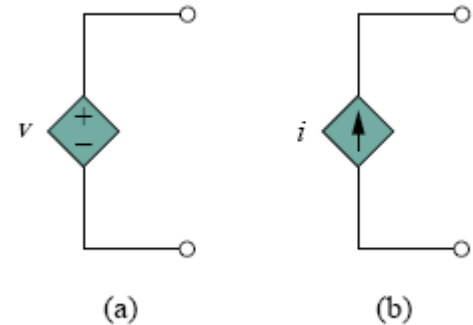



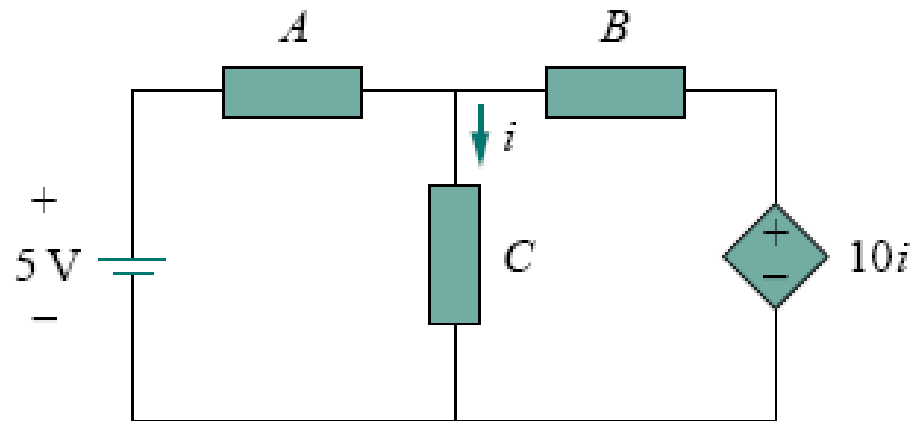















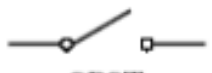
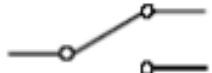

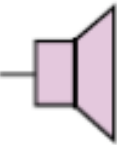
1. A voltage-controlled voltage source (VCVS).
2. A current-controlled voltage source (CCVS).
3. A voltage-controlled current source (VCCS).
4. A current-controlled current source (CCCS).



What kind of sources used in this fig?

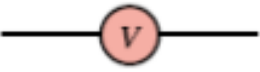
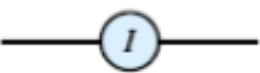
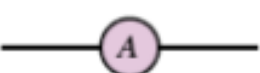
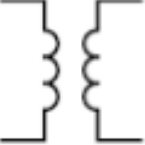

Schematic symbols

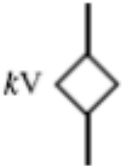
 Single cell  Multicell Batteries	 AC Voltage Source  Current Source	 Fixed  Variable Resistors	 Fixed  Variable Capacitors	 Air Core  Iron Core  Ferrite Core Inductors	
 Lamp	 SPST  SPDT Switches	 Microphone  Speaker	 Wires Joining  Wires Crossing	 Earth  Chassis Grounds	 Fuses 
 Circuit Breakers 	 Voltmeter  Ammeter  Ammeter	 Air Core  Iron Core  Ferrite Core Transformers	 Dependent Source		

Georg Ohm

Born: March 16, 1789, Bavaria, Germany

Died: July 6, 1854, Munich



The law was named after the German physicist [Georg Ohm](#), who, in a treatise published in 1827, described measurements of applied voltage and current through simple electrical circuits containing various lengths of wire. Ohm explained his experimental results by a slightly more complex equation than the modern form

OHM'S LAW

“Physical conditions remaining same, the potential drop between two ends of a conductor is directly proportional to the current flowing through it.”

or

$$V \propto I$$
$$V = RI$$

Where R is the constant of proportionality called Resistance
(ohms)

$$R = \frac{\rho \ell}{A}$$

where ρ - Resistivity of the material of conductor

ℓ - length of the conductor

A - Area of conductor

Gustav Robert Kirchhoff

Born: 12 March 1824 in Königsberg, Prussia
Died: 17 Oct 1887 in Berlin, Germany



Kirchhoff's laws, which he announced in 1845, allowed calculation of currents, voltages and resistances in electrical circuits with multiple loops, extending the work of [Ohm](#).

KIRCHOFF'S LAWS

KVL – Kirchoff's voltage law

- In a closed loop, the sum of potential raise is equal to potential drop or the algebraic sum of voltages around a closed path is equal to zero
- Through the source

Potential raise , +ve, current flows from '-ve' end to '+ve' end of the source and we go around the loop in the direction of current

Potential drop. -ve, current flows from '+ve' end to '-ve' end of the source and we go around the loop in the direction of current

- Through resistor

Always Current entering is positive

potential drop, -ve, when we go around the loop through the resistor from positive to negative

potential raise, +ve, when we go around the loop through the resistor from negative to positive

$$\sum V = 0$$

Things placed in parallel have same voltage drop across them

KCL – Kirchoff's Current law

- The sum of incoming currents is equal to sum of outgoing currents or the algebraic sum of currents meeting at node is equal to zero
- If current entering is taken '+ve', then current leaving the node is taken as '-ve'
- If current entering is taken '-ve', then current leaving the node is taken as '+ve'

$$\sum I = 0$$

This fundamental law results from the conservation of charge.

For a series circuit, the current is same everywhere

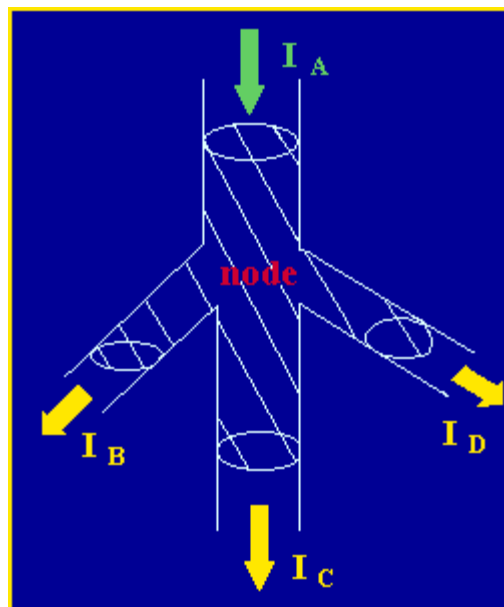

KCL

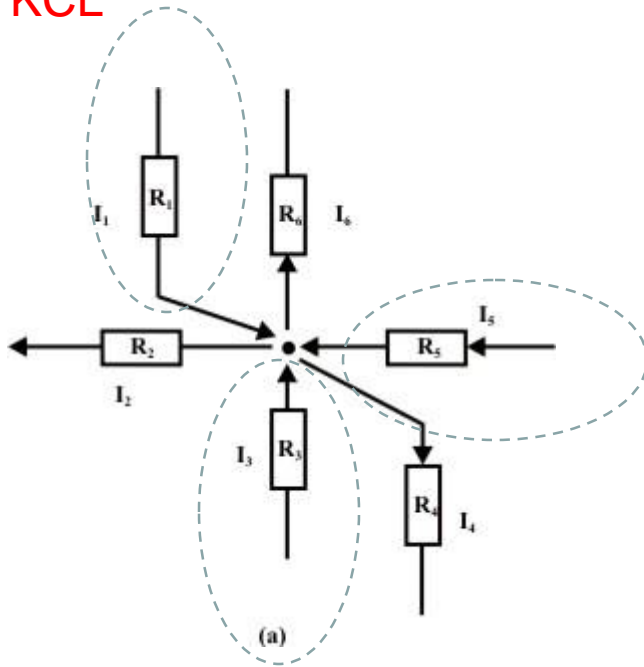

$$I_1 - I_2 + I_3 - I_4 + I_5 - I_6 = 0$$

or

$$I_1 + I_3 + I_5 = I_2 + I_4 + I_6$$

KVL

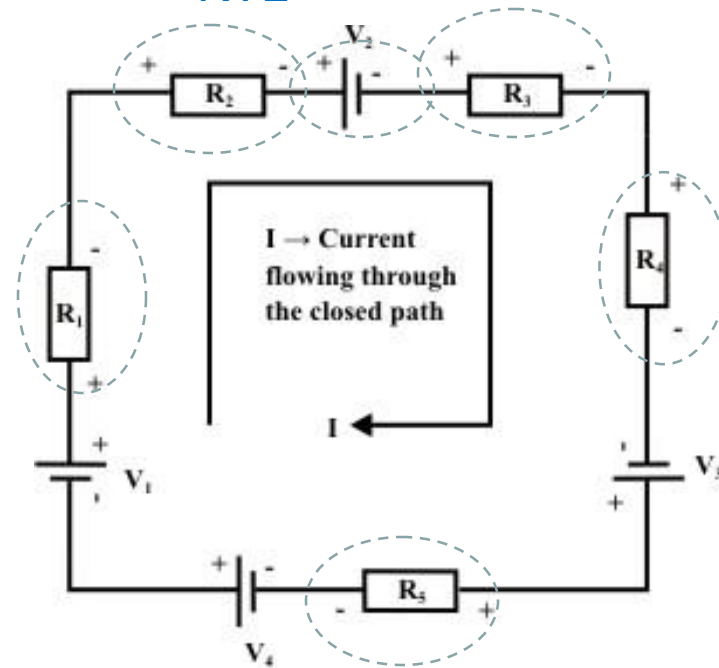

$$V_1 - IR_1 - IR_2 - V_2 - IR_3 - IR_4 + V_3 - IR_5 + V_4 = 0$$

or

$$V_1 + V_3 + V_4 = IR_1 + IR_2 + IR_3 + IR_4 + IR_5 + V_2$$

Important formulas/relationships

$$1 \text{ coulomb} = 6.24 \times 10^{18} \text{ electrons} \quad \text{volts} = \frac{\text{watts}}{\text{amperes}} = \frac{\text{joules/second}}{\text{amperes}} = \frac{\text{joules}}{\text{ampere seconds}} = \frac{\text{joules}}{\text{coulombs}}$$

$$Q = It$$

power, in watts

$$P = VI$$

$$\begin{aligned} \text{Electrical energy} &= \text{Power} \times \text{time} \\ &= VI t \text{ Joules} \end{aligned}$$

resistance, in ohms

$$R = \frac{V}{I}$$

conductance, in siemens

$$G = \frac{1}{R}$$

$$1 \text{ volt} = \frac{1 \text{ joule}}{\text{coulomb}}$$

power in watts,

$$P = \frac{W}{t}$$

energy, in joules,

$$W = Pt$$