

$$\Delta_2 = \begin{vmatrix} 3 & 12 & -1 \\ -4 & 0 & -1 \\ 2 & 0 & 1 \\ 3 & 12 & -1 \\ -4 & 0 & -1 \end{vmatrix} = 0 + 0 - 24 - 0 - 0 + 48 = 24$$

$$\Delta_3 = \begin{vmatrix} 3 & -2 & 12 \\ -4 & 7 & 0 \\ 2 & -3 & 0 \\ 3 & -2 & 12 \\ -4 & 7 & 0 \end{vmatrix} = 0 + 144 + 0 - 168 - 0 - 0 = -24$$

Thus, we find

$$v_1 = \frac{\Delta_1}{\Delta} = \frac{48}{10} = 4.8 \text{ V}, \quad v_2 = \frac{\Delta_2}{\Delta} = \frac{24}{10} = 2.4 \text{ V}$$

$$v_3 = \frac{\Delta_3}{\Delta} = \frac{-24}{10} = -2.4 \text{ V}$$

as we obtained with Method 1.

PRACTICE PROBLEM 3.2

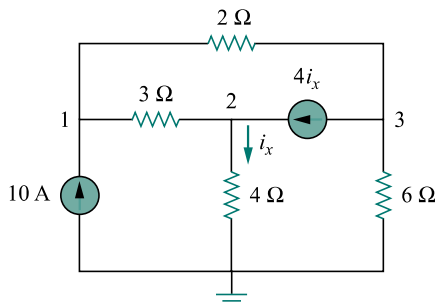

Figure 3.6 For Practice Prob. 3.2.

Find the voltages at the three nonreference nodes in the circuit of Fig. 3.6.

Answer: $v_1 = 80 \text{ V}$, $v_2 = -64 \text{ V}$, $v_3 = 156 \text{ V}$.

Electronic Testing Tutorials

3.3 NODAL ANALYSIS WITH VOLTAGE SOURCES

We now consider how voltage sources affect nodal analysis. We use the circuit in Fig. 3.7 for illustration. Consider the following two possibilities.

CASE 1 If a voltage source is connected between the reference node and a nonreference node, we simply set the voltage at the nonreference node equal to the voltage of the voltage source. In Fig. 3.7, for example,

$$v_1 = 10 \text{ V} \quad (3.10)$$

Thus our analysis is somewhat simplified by this knowledge of the voltage at this node.

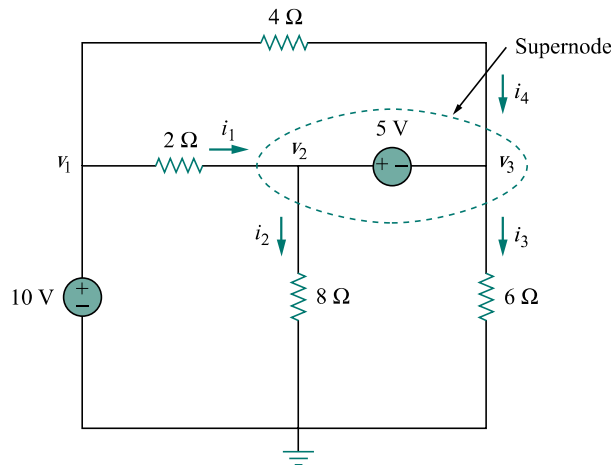

Figure 3.7 A circuit with a supernode.

CASE 2 If the voltage source (dependent or independent) is connected between two nonreference nodes, the two nonreference nodes form a *generalized node* or *supernode*; we apply both KCL and KVL to determine the node voltages.

A supernode may be regarded as a closed surface enclosing the voltage source and its two nodes.

A **supernode** is formed by enclosing a (dependent or independent) voltage source connected between two nonreference nodes and any elements connected in parallel with it.

In Fig. 3.7, nodes 2 and 3 form a supernode. (We could have more than two nodes forming a single supernode. For example, see the circuit in Fig. 3.14.) We analyze a circuit with supernodes using the same three steps mentioned in the previous section except that the supernodes are treated differently. Why? Because an essential component of nodal analysis is applying KCL, which requires knowing the current through each element. There is no way of knowing the current through a voltage source in advance. However, KCL must be satisfied at a supernode like any other node. Hence, at the supernode in Fig. 3.7,

$$i_1 + i_4 = i_2 + i_3 \quad (3.11a)$$

or

$$\frac{v_1 - v_2}{2} + \frac{v_1 - v_3}{4} = \frac{v_2 - 0}{8} + \frac{v_3 - 0}{6} \quad (3.11b)$$

To apply Kirchhoff's voltage law to the supernode in Fig. 3.7, we redraw the circuit as shown in Fig. 3.8. Going around the loop in the clockwise direction gives

$$-v_2 + 5 + v_3 = 0 \quad \Rightarrow \quad v_2 - v_3 = 5 \quad (3.12)$$

From Eqs. (3.10), (3.11b), and (3.12), we obtain the node voltages.

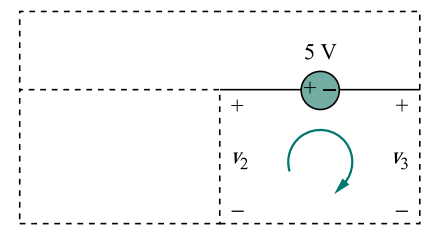

Figure 3.8 Applying KVL to a supernode.

Note the following properties of a supernode:

1. The voltage source inside the supernode provides a constraint equation needed to solve for the node voltages.
2. A supernode has no voltage of its own.
3. A supernode requires the application of both KCL and KVL.

EXAMPLE 3.3

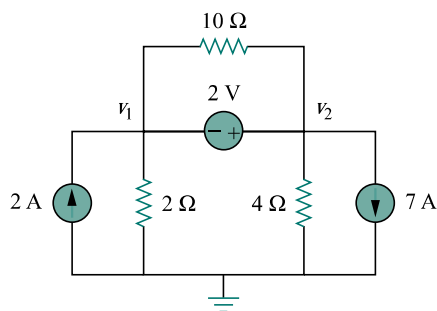

Figure 3.9 For Example 3.3.

For the circuit shown in Fig. 3.9, find the node voltages.

Solution:

The supernode contains the 2-V source, nodes 1 and 2, and the 10-Ω resistor. Applying KCL to the supernode as shown in Fig. 3.10(a) gives

$$2 = i_1 + i_2 + 7$$

Expressing i_1 and i_2 in terms of the node voltages

$$2 = \frac{v_1 - 0}{2} + \frac{v_2 - 0}{4} + 7 \quad \implies \quad 8 = 2v_1 + v_2 + 28$$

or

$$v_2 = -20 - 2v_1 \quad (3.3.1)$$

To get the relationship between v_1 and v_2 , we apply KVL to the circuit in Fig. 3.10(b). Going around the loop, we obtain

$$-v_1 - 2 + v_2 = 0 \quad \implies \quad v_2 = v_1 + 2 \quad (3.3.2)$$

From Eqs. (3.3.1) and (3.3.2), we write

$$v_2 = v_1 + 2 = -20 - 2v_1$$

or

$$3v_1 = -22 \quad \implies \quad v_1 = -7.333 \text{ V}$$

and $v_2 = v_1 + 2 = -5.333 \text{ V}$. Note that the 10-Ω resistor does not make any difference because it is connected across the supernode.

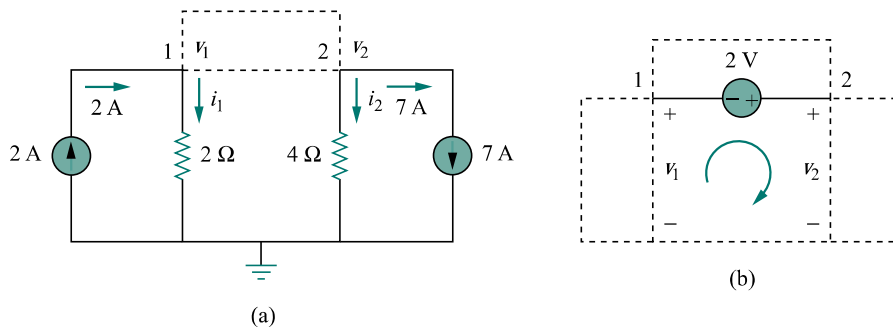

Figure 3.10 Applying: (a) KCL to the supernode, (b) KVL to the loop.

PRACTICE PROBLEM 3.3

Find v and i in the circuit in Fig. 3.11.

Answer: -0.2 V, 1.4 A.

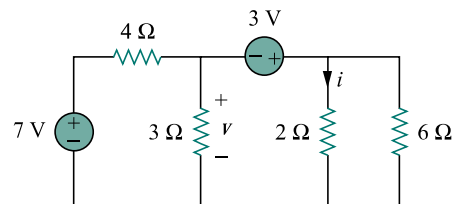

Figure 3.11 For Practice Prob. 3.3.

EXAMPLE 3.4

Find the node voltages in the circuit of Fig. 3.12.

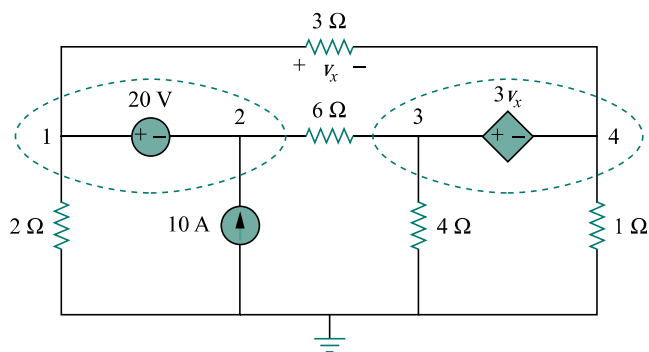

Figure 3.12 For Example 3.4.

Solution:

Nodes 1 and 2 form a supernode; so do nodes 3 and 4. We apply KCL to the two supernodes as in Fig. 3.13(a). At supernode 1-2,

$$i_3 + 10 = i_1 + i_2$$

Expressing this in terms of the node voltages,

$$\frac{v_3 - v_2}{6} + 10 = \frac{v_1 - v_4}{3} + \frac{v_1}{2}$$

or

$$5v_1 + v_2 - v_3 - 2v_4 = 60 \quad (3.4.1)$$

At supernode 3-4,

$$i_1 = i_3 + i_4 + i_5 \quad \Rightarrow \quad \frac{v_1 - v_4}{3} = \frac{v_3 - v_2}{6} + \frac{v_4}{1} + \frac{v_3}{4}$$

or

$$4v_1 + 2v_2 - 5v_3 - 16v_4 = 0 \quad (3.4.2)$$

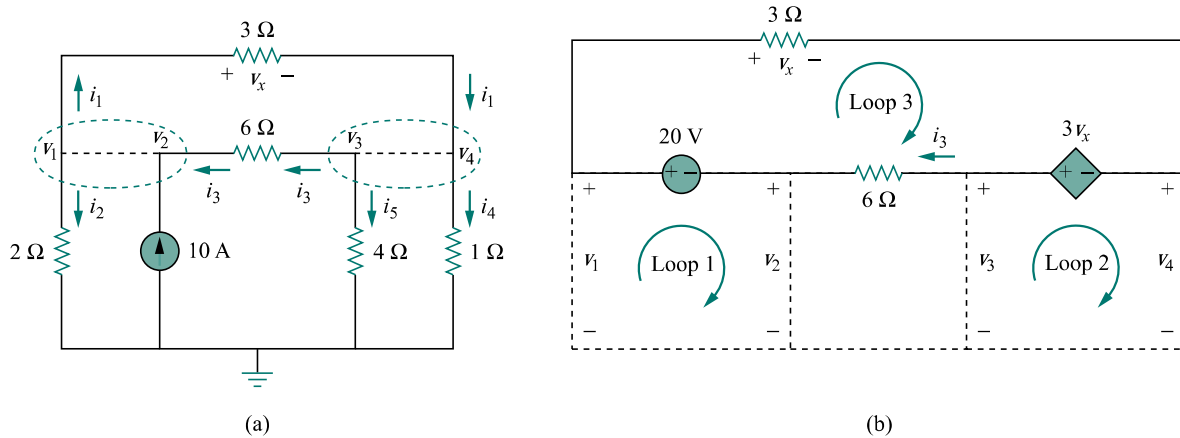

Figure 3.13 Applying: (a) KCL to the two supernodes, (b) KVL to the loops.

We now apply KVL to the branches involving the voltage sources as shown in Fig. 3.13(b). For loop 1,

$$-v_1 + 20 + v_2 = 0 \quad \implies \quad v_1 - v_2 = 20 \quad (3.4.3)$$

For loop 2,

$$-v_3 + 3v_x + v_4 = 0$$

But $v_x = v_1 - v_4$ so that

$$3v_1 - v_3 - 2v_4 = 0 \quad (3.4.4)$$

For loop 3,

$$v_x - 3v_x + 6i_3 - 20 = 0$$

But $6i_3 = v_3 - v_2$ and $v_x = v_1 - v_4$. Hence

$$-2v_1 - v_2 + v_3 + 2v_4 = 20 \quad (3.4.5)$$

We need four node voltages, v_1 , v_2 , v_3 , and v_4 , and it requires only four out of the five Eqs. (3.4.1) to (3.4.5) to find them. Although the fifth equation is redundant, it can be used to check results. We can eliminate one node voltage so that we solve three simultaneous equations instead of four. From Eq. (3.4.3), $v_2 = v_1 - 20$. Substituting this into Eqs. (3.4.1) and (3.4.2), respectively, gives

$$6v_1 - v_3 - 2v_4 = 80 \quad (3.4.6)$$

and

$$6v_1 - 5v_3 - 16v_4 = 40 \quad (3.4.7)$$

Equations (3.4.4), (3.4.6), and (3.4.7) can be cast in matrix form as

$$\begin{bmatrix} 3 & -1 & -2 \\ 6 & -1 & -2 \\ 6 & -5 & -16 \end{bmatrix} \begin{bmatrix} v_1 \\ v_3 \\ v_4 \end{bmatrix} = \begin{bmatrix} 0 \\ 80 \\ 40 \end{bmatrix}$$

Using Cramer's rule,

$$\Delta = \begin{vmatrix} 3 & -1 & -2 \\ 6 & -1 & -2 \\ 6 & -5 & -16 \end{vmatrix} = -18, \quad \Delta_1 = \begin{vmatrix} 0 & -1 & -2 \\ 80 & -1 & -2 \\ 40 & -5 & -16 \end{vmatrix} = -480$$

$$\Delta_3 = \begin{vmatrix} 3 & 0 & -2 \\ 6 & 80 & -2 \\ 6 & 40 & -16 \end{vmatrix} = -3120, \quad \Delta_4 = \begin{vmatrix} 3 & -1 & 0 \\ 6 & -1 & 80 \\ 6 & -5 & 40 \end{vmatrix} = 840$$

Thus, we arrive at the node voltages as

$$v_1 = \frac{\Delta_1}{\Delta} = \frac{-480}{-18} = 26.667 \text{ V}, \quad v_3 = \frac{\Delta_3}{\Delta} = \frac{-3120}{-18} = 173.333 \text{ V}$$

$$v_4 = \frac{\Delta_4}{\Delta} = \frac{840}{-18} = -46.667 \text{ V}$$

and $v_2 = v_1 - 20 = 6.667 \text{ V}$. We have not used Eq. (3.4.5); it can be used to cross check results.

PRACTICE PROBLEM 3.4

Find v_1 , v_2 , and v_3 in the circuit in Fig. 3.14 using nodal analysis.

Answer: $v_1 = 3.043 \text{ V}$, $v_2 = -6.956 \text{ V}$, $v_3 = 0.6522 \text{ V}$.

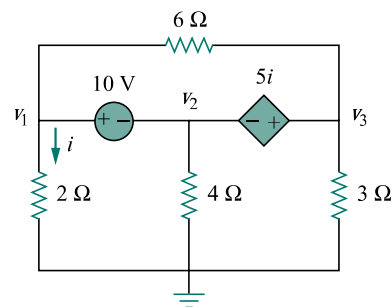

Figure 3.14 For Practice Prob. 3.4.

3.4 MESH ANALYSIS

Mesh analysis provides another general procedure for analyzing circuits, using mesh currents as the circuit variables. Using mesh currents instead of element currents as circuit variables is convenient and reduces the number of equations that must be solved simultaneously. Recall that a loop is a closed path with no node passed more than once. A mesh is a loop that does not contain any other loop within it.

Nodal analysis applies KCL to find unknown voltages in a given circuit, while mesh analysis applies KVL to find unknown currents. Mesh analysis is not quite as general as nodal analysis because it is only applicable to a circuit that is *planar*. A planar circuit is one that can be drawn in a plane with no branches crossing one another; otherwise it is *nonplanar*. A circuit may have crossing branches and still be planar if it can be redrawn such that it has no crossing branches. For example, the



Network Analysis

Electronic Testing Tutorials

Mesh analysis is also known as *loop analysis* or the *mesh-current method*.

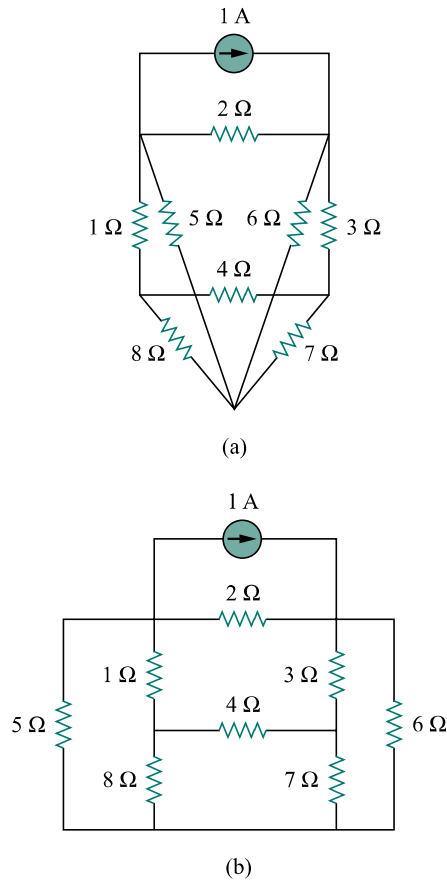

Figure 3.15 (a) A planar circuit with crossing branches, (b) the same circuit redrawn with no crossing branches.

Although path $abcdefa$ is a loop and not a mesh, KVL still holds. This is the reason for loosely using the terms *loop analysis* and *mesh analysis* to mean the same thing.

circuit in Fig. 3.15(a) has two crossing branches, but it can be redrawn as in Fig. 3.15(b). Hence, the circuit in Fig. 3.15(a) is planar. However, the circuit in Fig. 3.16 is nonplanar, because there is no way to redraw it and avoid the branches crossing. Nonplanar circuits can be handled using nodal analysis, but they will not be considered in this text.

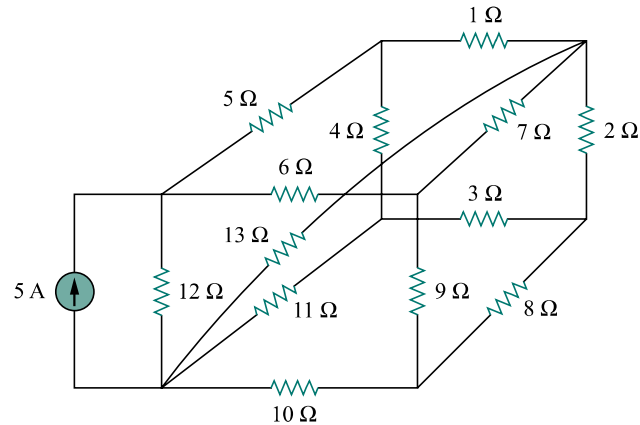

Figure 3.16 A nonplanar circuit.

To understand mesh analysis, we should first explain more about what we mean by a mesh.

A **mesh** is a loop which does not contain any other loops within it.

In Fig. 3.17, for example, paths $abefa$ and $bcdeb$ are meshes, but path $abcdefa$ is not a mesh. The current through a mesh is known as *mesh current*. In mesh analysis, we are interested in applying KVL to find the mesh currents in a given circuit.

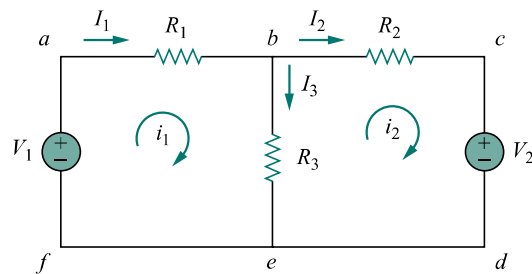

Figure 3.17 A circuit with two meshes.

In this section, we will apply mesh analysis to planar circuits that do not contain current sources. In the next sections, we will consider circuits with current sources. In the mesh analysis of a circuit with n meshes, we take the following three steps.

Steps to Determine Mesh Currents:

1. Assign mesh currents i_1, i_2, \dots, i_n to the n meshes.
2. Apply KVL to each of the n meshes. Use Ohm's law to express the voltages in terms of the mesh currents.
3. Solve the resulting n simultaneous equations to get the mesh currents.

To illustrate the steps, consider the circuit in Fig. 3.17. The first step requires that mesh currents i_1 and i_2 are assigned to meshes 1 and 2. Although a mesh current may be assigned to each mesh in an arbitrary direction, it is conventional to assume that each mesh current flows clockwise.

As the second step, we apply KVL to each mesh. Applying KVL to mesh 1, we obtain

$$-V_1 + R_1 i_1 + R_3(i_1 - i_2) = 0$$

or

$$(R_1 + R_3)i_1 - R_3 i_2 = V_1 \quad (3.13)$$

For mesh 2, applying KVL gives

$$R_2 i_2 + V_2 + R_3(i_2 - i_1) = 0$$

or

$$-R_3 i_1 + (R_2 + R_3)i_2 = -V_2 \quad (3.14)$$

Note in Eq. (3.13) that the coefficient of i_1 is the sum of the resistances in the first mesh, while the coefficient of i_2 is the negative of the resistance common to meshes 1 and 2. Now observe that the same is true in Eq. (3.14). This can serve as a shortcut way of writing the mesh equations. We will exploit this idea in Section 3.6.

The third step is to solve for the mesh currents. Putting Eqs. (3.13) and (3.14) in matrix form yields

$$\begin{bmatrix} R_1 + R_3 & -R_3 \\ -R_3 & R_2 + R_3 \end{bmatrix} \begin{bmatrix} i_1 \\ i_2 \end{bmatrix} = \begin{bmatrix} V_1 \\ -V_2 \end{bmatrix} \quad (3.15)$$

which can be solved to obtain the mesh currents i_1 and i_2 . We are at liberty to use any technique for solving the simultaneous equations. According to Eq. (2.12), if a circuit has n nodes, b branches, and l independent loops or meshes, then $l = b - n + 1$. Hence, l independent simultaneous equations are required to solve the circuit using mesh analysis.

Notice that the branch currents are different from the mesh currents unless the mesh is isolated. To distinguish between the two types of currents, we use i for a mesh current and I for a branch current. The current elements I_1 , I_2 , and I_3 are algebraic sums of the mesh currents. It is evident from Fig. 3.17 that

$$I_1 = i_1, \quad I_2 = i_2, \quad I_3 = i_1 - i_2 \quad (3.16)$$

The direction of the mesh current is arbitrary—(clockwise or counterclockwise)—and does not affect the validity of the solution.

The shortcut way will not apply if one mesh current is assumed clockwise and the other assumed anticlockwise, although this is permissible.

EXAMPLE 3.5

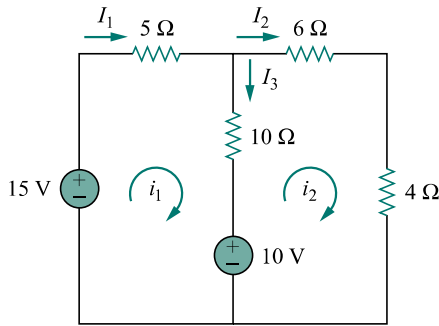

Figure 3.18 For Example 3.5.

For the circuit in Fig. 3.18, find the branch currents I_1 , I_2 , and I_3 using mesh analysis.

Solution:

We first obtain the mesh currents using KVL. For mesh 1,

$$-15 + 5i_1 + 10(i_1 - i_2) + 10 = 0$$

or

$$3i_1 - 2i_2 = 1 \quad (3.5.1)$$

For mesh 2,

$$6i_2 + 4i_2 + 10(i_2 - i_1) - 10 = 0$$

or

$$i_1 = 2i_2 - 1 \quad (3.5.2)$$

METHOD 1 Using the substitution method, we substitute Eq. (3.5.2) into Eq. (3.5.1), and write

$$6i_2 - 3 - 2i_2 = 1 \quad \implies \quad i_2 = 1 \text{ A}$$

From Eq. (3.5.2), $i_1 = 2i_2 - 1 = 2 - 1 = 1 \text{ A}$. Thus,

$$I_1 = i_1 = 1 \text{ A}, \quad I_2 = i_2 = 1 \text{ A}, \quad I_3 = i_1 - i_2 = 0$$

METHOD 2 To use Cramer's rule, we cast Eqs. (3.5.1) and (3.5.2) in matrix form as

$$\begin{bmatrix} 3 & -2 \\ -1 & 2 \end{bmatrix} \begin{bmatrix} i_1 \\ i_2 \end{bmatrix} = \begin{bmatrix} 1 \\ 1 \end{bmatrix}$$

We obtain the determinants

$$\Delta = \begin{vmatrix} 3 & -2 \\ -1 & 2 \end{vmatrix} = 6 - 2 = 4$$

$$\Delta_1 = \begin{vmatrix} 1 & -2 \\ 1 & 2 \end{vmatrix} = 2 + 2 = 4, \quad \Delta_2 = \begin{vmatrix} 3 & 1 \\ -1 & 1 \end{vmatrix} = 3 + 1 = 4$$

Thus,

$$i_1 = \frac{\Delta_1}{\Delta} = 1 \text{ A}, \quad i_2 = \frac{\Delta_2}{\Delta} = 1 \text{ A}$$

as before.

PRACTICE PROBLEM 3.5

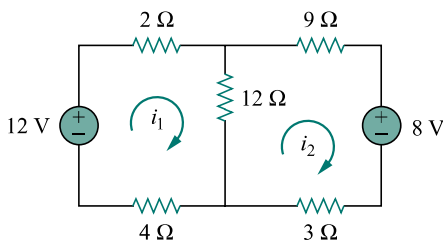

Figure 3.19 For Practice Prob. 3.5.

Calculate the mesh currents i_1 and i_2 in the circuit of Fig. 3.19.

Answer: $i_1 = \frac{2}{3} \text{ A}$, $i_2 = 0 \text{ A}$.

EXAMPLE 3.6

Use mesh analysis to find the current i_o in the circuit in Fig. 3.20.

Solution:

We apply KVL to the three meshes in turn. For mesh 1,

$$-24 + 10(i_1 - i_2) + 12(i_1 - i_3) = 0$$

or

$$11i_1 - 5i_2 - 6i_3 = 12$$

For mesh 2,

$$24i_2 + 4(i_2 - i_3) + 10(i_2 - i_1) = 0$$

or

$$-5i_1 + 19i_2 - 2i_3 = 0$$

For mesh 3,

$$4i_o + 12(i_3 - i_1) + 4(i_3 - i_2) = 0$$

But at node A, $i_o = i_1 - i_2$, so that

$$4(i_1 - i_2) + 12(i_3 - i_1) + 4(i_3 - i_2) = 0$$

or

$$-i_1 - i_2 + 2i_3 = 0$$

In matrix form, Eqs. (3.6.1) to (3.6.3) become

$$\begin{bmatrix} 11 & -5 & -6 \\ -5 & 19 & -2 \\ -1 & -1 & 2 \end{bmatrix} \begin{bmatrix} i_1 \\ i_2 \\ i_3 \end{bmatrix} = \begin{bmatrix} 12 \\ 0 \\ 0 \end{bmatrix}$$

We obtain the determinants as

$$\Delta = \begin{vmatrix} 11 & -5 & -6 \\ -5 & 19 & -2 \\ -1 & -1 & 2 \end{vmatrix} = 418 - 30 - 10 - 114 - 22 - 50 = 192$$

$$\Delta_1 = \begin{vmatrix} 12 & -5 & -6 \\ 0 & 19 & -2 \\ 0 & -1 & 2 \end{vmatrix} = 456 - 24 = 432$$

$$\Delta_2 = \begin{vmatrix} 11 & 12 & -6 \\ -5 & 0 & -2 \\ -1 & 0 & 2 \end{vmatrix} = 24 + 120 = 144$$

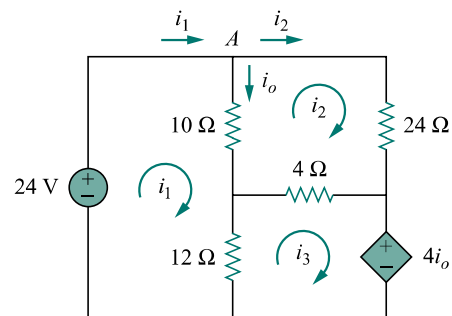

Figure 3.20 For Example 3.6.

$$\Delta_3 = \begin{vmatrix} 11 & -5 & 12 \\ -5 & 19 & 0 \\ -1 & -1 & 0 \end{vmatrix} = 60 + 228 = 288$$

We calculate the mesh currents using Cramer's rule as

$$i_1 = \frac{\Delta_1}{\Delta} = \frac{432}{192} = 2.25 \text{ A}, \quad i_2 = \frac{\Delta_2}{\Delta} = \frac{144}{192} = 0.75 \text{ A}$$

$$i_3 = \frac{\Delta_3}{\Delta} = \frac{288}{192} = 1.5 \text{ A}$$

Thus, $i_o = i_1 - i_2 = 1.5 \text{ A}$.

PRACTICE PROBLEM 3.6

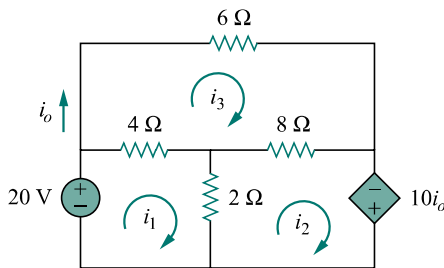

Figure 3.21 For Practice Prob. 3.6.

Using mesh analysis, find i_o in the circuit in Fig. 3.21.

Answer: -5 A .

Electronic Testing Tutorials

3.5 MESH ANALYSIS WITH CURRENT SOURCES

Applying mesh analysis to circuits containing current sources (dependent or independent) may appear complicated. But it is actually much easier than what we encountered in the previous section, because the presence of the current sources reduces the number of equations. Consider the following two possible cases.

CASE 1 When a current source exists only in one mesh: Consider the circuit in Fig. 3.22, for example. We set $i_2 = -5 \text{ A}$ and write a mesh equation for the other mesh in the usual way, that is,

$$-10 + 4i_1 + 6(i_1 - i_2) = 0 \quad \implies \quad i_1 = -2 \text{ A} \quad (3.17)$$

CASE 2 When a current source exists between two meshes: Consider the circuit in Fig. 3.23(a), for example. We create a *supermesh* by excluding the current source and any elements connected in series with it, as shown in Fig. 3.23(b). Thus,

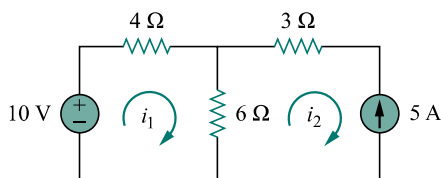

Figure 3.22 A circuit with a current source.

A *supermesh* results when two meshes have a (dependent or independent) current source in common.

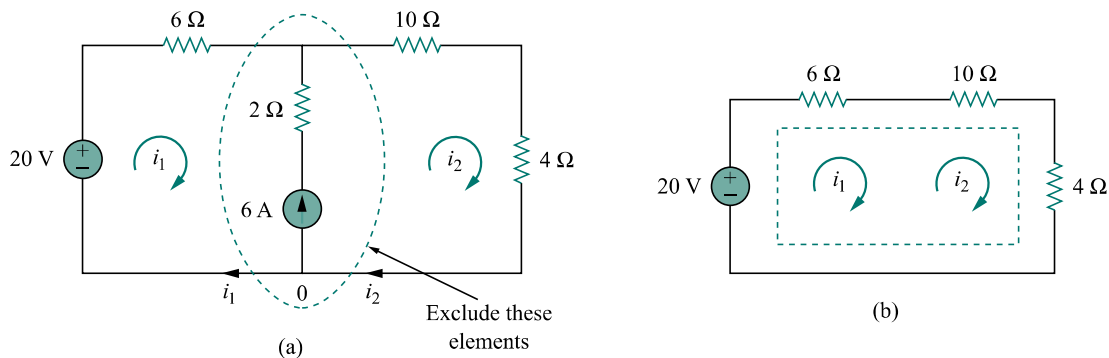

Figure 3.23 (a) Two meshes having a current source in common, (b) a supermesh, created by excluding the current source.

As shown in Fig. 3.23(b), we create a supermesh as the periphery of the two meshes and treat it differently. (If a circuit has two or more supermeshes that intersect, they should be combined to form a larger supermesh.) Why treat the supermesh differently? Because mesh analysis applies KVL—which requires that we know the voltage across each branch—and we do not know the voltage across a current source in advance. However, a supermesh must satisfy KVL like any other mesh. Therefore, applying KVL to the supermesh in Fig. 3.23(b) gives

$$-20 + 6i_1 + 10i_2 + 4i_2 = 0$$

or

$$6i_1 + 14i_2 = 20 \quad (3.18)$$

We apply KCL to a node in the branch where the two meshes intersect. Applying KCL to node 0 in Fig. 3.23(a) gives

$$i_2 = i_1 + 6 \quad (3.19)$$

Solving Eqs. (3.18) and (3.19), we get

$$i_1 = -3.2 \text{ A}, \quad i_2 = 2.8 \text{ A} \quad (3.20)$$

Note the following properties of a supermesh:

1. The current source in the supermesh is not completely ignored; it provides the constraint equation necessary to solve for the mesh currents.
2. A supermesh has no current of its own.
3. A supermesh requires the application of both KVL and KCL.

EXAMPLE 3.7

For the circuit in Fig. 3.24, find i_1 to i_4 using mesh analysis.

Solution:

Note that meshes 1 and 2 form a supermesh since they have an independent current source in common. Also, meshes 2 and 3 form another supermesh

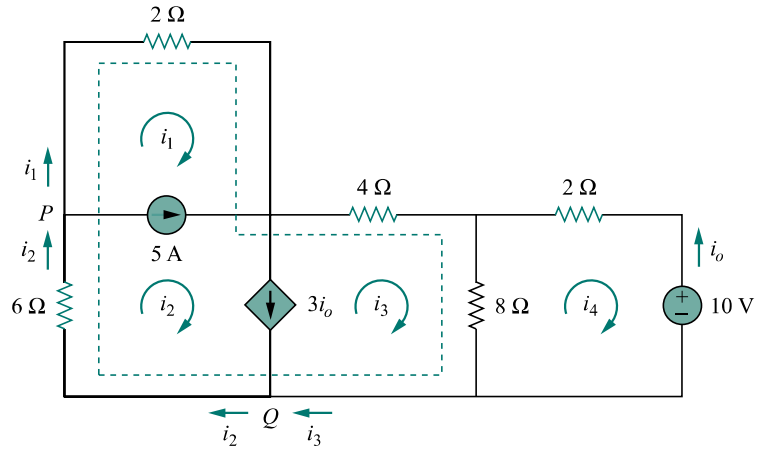

Figure 3.24 For Example 3.7.

because they have a dependent current source in common. The two supermeshes intersect and form a larger supermesh as shown. Applying KVL to the larger supermesh,

$$2i_1 + 4i_3 + 8(i_3 - i_4) + 6i_2 = 0$$

or

$$i_1 + 3i_2 + 6i_3 - 4i_4 = 0 \quad (3.7.1)$$

For the independent current source, we apply KCL to node P :

$$i_2 = i_1 + 5 \quad (3.7.2)$$

For the dependent current source, we apply KCL to node Q :

$$i_2 = i_3 + 3i_o$$

But $i_o = -i_4$, hence,

$$i_2 = i_3 - 3i_4 \quad (3.7.3)$$

Applying KVL in mesh 4,

$$2i_4 + 8(i_4 - i_3) + 10 = 0$$

or

$$5i_4 - 4i_3 = -5 \quad (3.7.4)$$

From Eqs. (3.7.1) to (3.7.4),

$$i_1 = -7.5 \text{ A}, \quad i_2 = -2.5 \text{ A}, \quad i_3 = 3.93 \text{ A}, \quad i_4 = 2.143 \text{ A}$$

PRACTICE PROBLEM 3.7

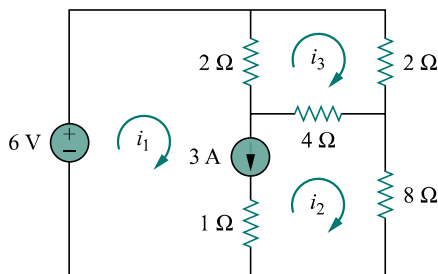

Use mesh analysis to determine i_1 , i_2 , and i_3 in Fig. 3.25.

Answer: $i_1 = 3.474 \text{ A}$, $i_2 = 0.4737 \text{ A}$, $i_3 = 1.1052 \text{ A}$.



Network Analysis

Figure 3.25 For Practice Prob. 3.7.