



SCHOOL OF ELECTRICAL ENGINEERING

CONTINUOUS ASSESSMENT TEST – I
WINTER SEMESTER 2022-2023 (Freshers)

Programme Name & Branch: B.Tech, FFCS

Course Code: BEEE 102L

Course Name: Basic Electrical and Electronics Engineering

Faculty Name(s): Prof. Razia Sultana, Prof. Vanishree, Prof. Thamilmaran, Prof. Raju J., Prof. Subramanian K., Prof. Mageshvaran R., Prof. Chilukuri Venkata Mahendra, Prof. Brisilla R. M., Prof. Sonam Shrivastava, Prof. Satyajit Das, Prof. Thiruvankadam S., Prof. Mallikarjuna Golla, Prof. Mrutunjaya Panda, Prof. Raghuram M.

Class Number(s): VL2022230504429, 4440, 4453, 4467, 4466, 4466, 4468, 4473, 4474, 4475, 4479, 4483,

Date: 29/03/2023

Exam Duration: 90 minutes

Maximum Marks: 50

General instruction(s): Answer all the questions

Q.No	Question	Mark
1.	<p>For the circuit shown in Fig. 1, find the current I using Star-Delta transformation.</p> <p>Fig.1</p>	10
2.	<p>Using Mesh analysis in the circuit shown in Fig.2 find the all the mesh currents and also find power dissipated across $20\ \Omega$ resistor.</p> <p>Fig.2</p>	10

3. Find the value of R in the circuit shown in Fig. 3 using maximum power transfer theorem and also find the maximum power dissipated across it.

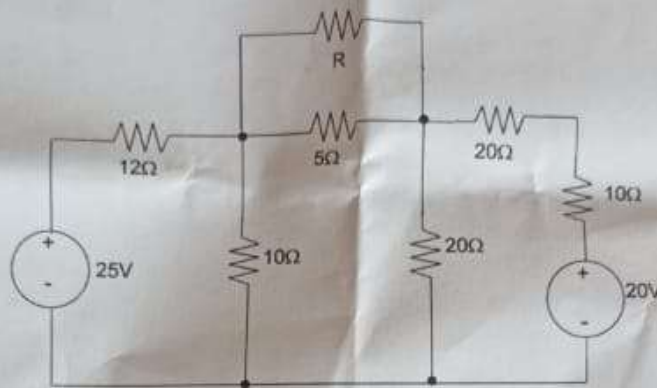

Fig. 3

10

4. Find the capacitance which must be connected in series with 100W, 110V lamp, in order that the lamp may draw its normal current when the combination is connected to a 230V, 50Hz supply. Also determine voltage across the capacitor, power factor and also draw the phasor diagram

10

5. The source voltage of 230V, 50Hz is supplied to the circuit shown in Fig. 4,
 a. Calculate total impedance Z and current I
 b. Calculate V_R , V_L and V_C
 c. Calculate circuit power factor

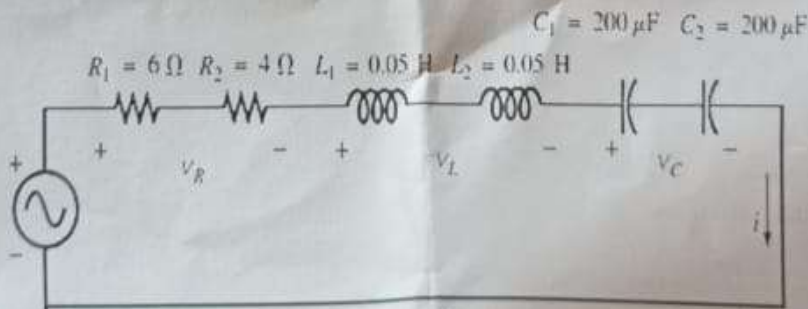

Fig.4

10