

Roll No.: 23BDS0055

Name: Yash Hirani

Experiment No.: 10

Date: 21/3/2024

DESIGN OF HALFADDER DIGITAL CIRCUIT USING LOGIC GATES

Aim

To design and verify a half adder using logic gates.

Apparatus/ Tool Required

S. No.	Name of the apparatus	Range / Type	Quantity
1	IC 7486	-	1 No.
2	IC 7408	-	1 No.
3	LED	-	2 Nos.
4	RPS	0 – 15 V	1 No.
5	Resistor	330 Ω	2 Nos.
6	Breadboard	-	1 No.
7	Wires	-	Few

Theory

Half- Adder Circuit

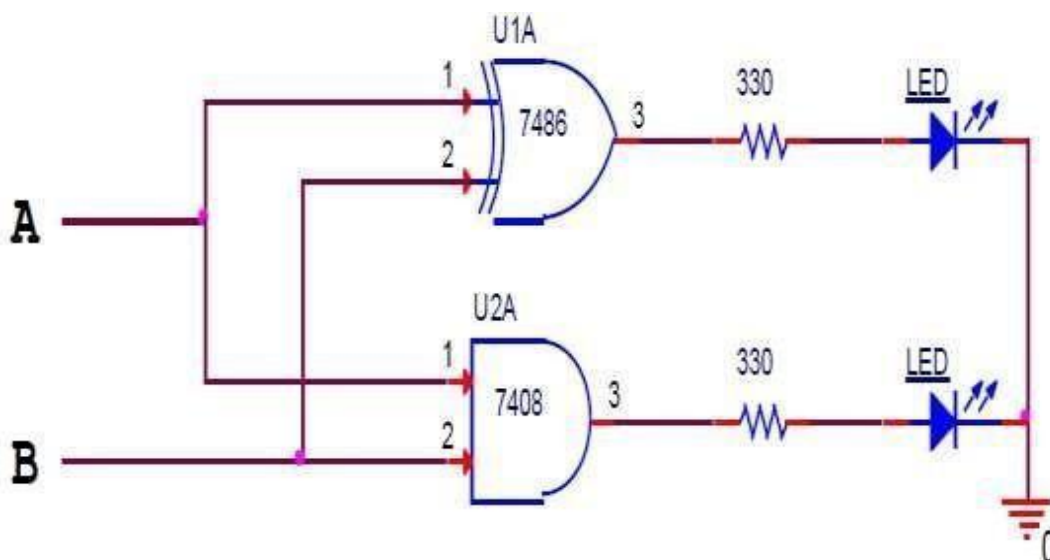

Truth Table

A	B	$S=A\oplus B$	$C=A.B$
0	0	0	0
0	1	1	0
1	0	1	0
1	1	1	1

Photograph of the practical circuit done in the lab

1) FOR INPUT 0 AND 0:



2) FOR INPUT 0 AND 1:



3) FOR INPUTS 1 AND 0:



4) FOR INPUTS 1 AND 1:



Procedure

1. Connect the circuit as shown in figure.
2. Apply voltages to inputs A and B as represented in the truth table and verify the truth table

Result:

Verified the working of half adder circuit with working of logic gates using LED's to visualise the output.

Summary

Half adder is a logic gate that adds two bits and produces the output, sum and carry. Sum produces 1 when A & B are different and carry is 1 when A & B are 1. The expected output has been verified.