



VIT[®]

Vellore Institute of Technology
(Deemed to be University under section 3 of UGC Act, 1956)

SCHOOL OF ELECTRICAL ENGINEERING
CONTINUOUS ASSESSMENT TEST - I
FALL SEMESTER 2025 -2026

REG.NO.:

SLOT: A1

Programme Name & Branch : B. Tech EEE, EIE & ECS
 Course Code and Course Name : BEEE203L Circuit Theory
 Faculty Name(s) : Dr. P. Vijayapriya, Dr. K. Palanisamy, Dr. J. Vanishree
 Class Number : VL2025260101016, 1017, 1095
 Date of Examination : 17.8.2025
 Exam Duration : 90 minutes Maximum Marks: 50

General instruction(s):

- Answer All Questions
- M - Max mark; CO – Course Outcome; BL – Blooms Taxonomy Level
- Course Outcomes
 1. Understand the network topology and to apply the network theorems to estimate the steady state response for a given excitation.
 2. Analyze three = phase unbalanced systems in star and delta configurations.

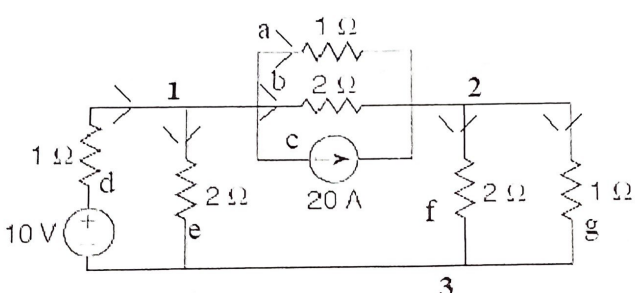
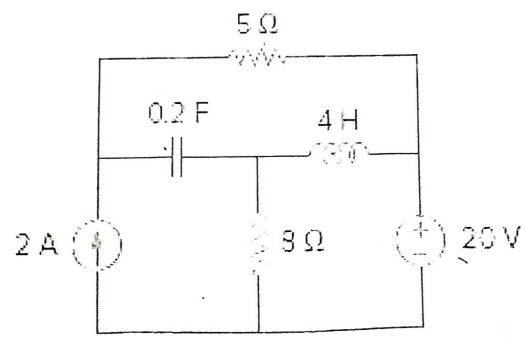
Q. No	Question	M	CO	BL
1.	<p>For the network shown in Fig.1, write the incidence matrix, f-tieset matrix and f-cutset matrix (Take the two vertical branches of 2 ohms as the tree)</p>  <p style="text-align: center;">Fig. 1.</p>	10	1	3
2.a)	<p>Draw the Dual circuit for the Fig. 2 shown below.</p>  <p style="text-align: center;">Fig. 2.</p>	5	1	3



VIT

Vellore Institute of Technology
(Declared as a University under section 3 of UGC Act 1956)

SCHOOL OF ELECTRICAL ENGINEERING
CONTINUOUS ASSESSMENT TEST - I
FALL SEMESTER 2025 -2026

REG.NO.:

SLOT: **A1**

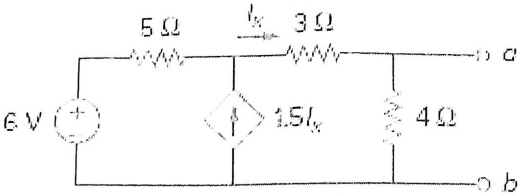
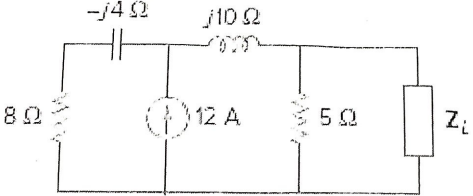
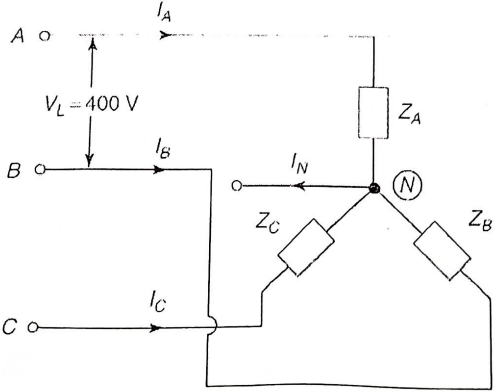
<p>2.b)</p>	<p>For the given incidence matrix, draw the oriented graph.</p> $ \begin{matrix} & 1 & 2 & 3 & 4 & 5 & 6 & 7 & 8 \\ a & \left[\begin{array}{cccccccc} 1 & 0 & 0 & 0 & 1 & 0 & 0 & 1 \\ 0 & 1 & 0 & 0 & -1 & 1 & 0 & 0 \\ 0 & 0 & 1 & 0 & 0 & -1 & 1 & -1 \\ 0 & 0 & 0 & 1 & 0 & 0 & -1 & 0 \end{array} \right] \end{matrix} $	5	1	3
<p>3.</p>	<p>Find the Thevenin's equivalent of the circuit across terminals ab in the Fig.3 given below .</p>  <p style="text-align: center;">Fig. 3</p>	10	1	3
<p>4.</p>	<p>Find the value of Maximum power that can be transferred to the load in the circuit given in Fig. 4.</p>  <p style="text-align: center;">Fig. 4</p>	10	1	3
<p>5.</p>	<p>A three-phase, 400 V, 4-wire system has a star-connected load with $Z_A = (10 + j0) \Omega$, $Z_B = (15 + j10) \Omega$, $Z_C = (0 + j5) \Omega$. Find the line currents and current through neutral conductor.</p>  <p style="text-align: center;">Fig. 5</p>	10	2	3